

SERVICING STANDARDS
FOR THE
TOWNSHIP OF ZORRA



SERVICING STANDARDS
FOR
THE TOWNSHIP OF ZORRA

**SERVICING STANDARDS
FOR
THE TOWNSHIP OF ZORRA**

General Requirements

These Servicing Standards provide for the standardization of the design and construction of roads, sanitary sewers, storm sewers, watermains, and lot grading in the Township of Zorra. These standards shall be used in the design and construction of the above-mentioned services. Deviations from these standards will be acceptable only under unusual circumstances and shall be approved in writing by the Township's Engineer.

Construction of the proposed work shall not commence until the following conditions have been met:

- 1) the Plans and Specifications have been approved, in writing, by the Township's Engineer, the County of Oxford (if applicable), and any applicable conservation authorities or regulating agencies;
- 2) the Plan of Subdivision has been registered;
- 3) approval has been granted by the Ministry of the Environment by means of a Certificate of Approval for proposed sanitary sewers, storm sewers, stormwater management and/or watermains.
- 4) the Development Agreement has been executed;
- 5) a signed and executed copy of the Contract Document(s) between the Contractor and the Developer have been submitted to the Township.

The Developer shall retain a professional Consulting Engineer licensed in the Province of Ontario for the design and preparation of the Contract Drawings and Specifications.

The Developer's Consulting Engineer shall be available for consultation as required during the construction period. The Developer's Consulting Engineer shall also provide full time resident inspection of the installation of the works, including submission of "as-built" drawings of the constructed works to the Township.

The Developer shall also provide details of: the existing soil conditions; material testing; compaction and exfiltration tests; and pressure testing as required by the Township.

The Developer's Consulting Engineer shall provide the Township with written certification that the constructed works have been completed in conformance with the approved Contract Drawings and Specifications.

SECTION 1 - ROADS

1.1 General

All roads shall be designed and constructed in accordance with the current edition of the "Manual of Geometric Design Standards for Canadian Roads" as published by the Roads and Transportation Association of Canada.

1.2 Street Classification

Street Classification for residential roadways (rural or urban) shall be based on the traffic volume and number of houses with access onto the street as follows:

Street Auto-Oriented Classification	Estimated Daily* No. of Houses	Traffic Volume
Minor-Local	up to 25	0 - 250
Local	up to 100	0 - 1000
Collector	100 - up	1000 - 3000
Arterial	--	3000 - up

* Traffic volumes are based on trips per household as follows:

Single Family	8-10 per day
Multi-Family	7-9 per day
Apartment	6-8 per day

1.3 Road Allowance, Pavement Widths, Location and Layout

- a) The minimum width of road allowances and pavement width is shown below:

Street Classification	Minimum Road Allowance	Minimum Pavement Width
Local & Minor-Local	20.00 m	8.0 m
Cul-De-Sac	20.00m	7.0 m
Collector	26.00 m	9.2 m
Arterial	30.48 m	9.2 m
Industrial	26.00 m	9.7 m

- b) Intersections of more than two streets shall not be permitted.
- c) Streets should intersect at right angles with each other.
- d) Jogged intersections will not be permitted.
- e) Street intersections shall not be closer than 60 m.
- f) ZSD 1, ZSD 2 and ZSD 3 show the standard utility locations for residential and industrial roads.
- g) The maximum length of a cul-de-sac to the turning circle shall be 215 m without a secondary or emergency access. ZSD 4 and ZSD 5 show typical residential cul-de-sacs and industrial cul-de-sacs respectively.
- h) Local street patterns should be planned to minimize through traffic and also minimize dead ends.

- i) The street system should clearly indicate the characteristic nature and function of the road.

1.4 Grades

- a) The maximum and minimum vertical road grades are 8% and 0.5% respectively, for new developing subdivisions.
- b) Vertical curves are required if the algebraic difference in grades is greater than 1%. The minimum length of the vertical curve shall not be less than 45 m.
- c) Road grades at intersections shall not exceed 2% across the intersection.
- d) All roadways shall be crowned on a 2% slope.
- e) Boulevards are to be sloped from the property line to the edge of the roadway at 2% to 6% (10% maximum on approval).
- f) Road shoulders shall be sloped from the edge of roadway at a 6% slope.

1.5 Design and Construction

- a) Cross-Sections

Typical cross-sections of residential subdivision streets shall conform to the details shown on ZSD 6 and ZSD 7. Typical cross-sections of industrial subdivision streets shall conform to the details shown on ZSD 8.

b) Pavement and Granular Base

i) The gradation requirements, placing and compaction of granular materials are to conform to the current O.P.S. Specifications, O.P.S.S. 314. Hot-mix, hot-laid asphalt shall conform to the current O.P.S. Specifications, O.P.S.S. 310.

ii) An engineered design for residential, industrial, commercial, and arterial roads based on geotechnical data must be submitted to the Township for review.

iii) For residential roads the following minimum compacted depths of granular and asphaltic pavement courses shall be provided:

40 mm HL3 Asphaltic Concrete compacted to 97% Marshall Density

50 mm HL8 Asphaltic Concrete compacted to 97% Marshall Density

150 mm Granular 'A' Base compacted to 100% S.P.M.D.D.

300 mm Granular 'B' Sub-base compacted to 100% S.P.M.D.D.

and shall be designed in accordance with the recommendations of a Geotechnical Engineer.

iv) Compaction

Compaction for earth fill and native backfill material forming the road subgrade shall be 98% Standard Proctor Density.

Compaction for granular materials in base course construction shall be 100% Standard Proctor Density.

Compaction for all asphalt materials shall be 97% Marshall Density.

v) Road Cuts

The edges of all paved and concrete surfaces to remain must be properly saw cut prior to removal.

c) Subdrains

Two 150mm dia. pipe sub-drains with a minimum 3 meter length shall be installed opposite to each other (parallel to the curb and gutter), for all catchbasins installed.

Pipe sub-drain shall be perforated corrugated polyethylene tubing with knit filter sock conforming to the requirements of OPSS 1840/1860 or perforated CSP (OPSS 1801) and installed in accordance with OPSD-216.03. Bedding and backfill material shall be coarse sand or approved granular material conforming to the requirements of OPSS 405. All sub-drains to have an approved geotextile around them together with an approved end cap.

d) Engineered Fill

Following the removal of the topsoil and any fill material, the subgrade should be thoroughly proof-rolled and inspected by a geotechnical engineer. Any loose or soft zones noted in the inspection should be sub-excavated and replaced with approved inorganic fill.

Grades can then be restored with compacted fill material. Any required fill material should be inspected and approved by a geotechnical engineer and should be placed in maximum 300mm (12 inch) thick lifts and uniformly compacted to 100 percent Standard Proctor Maximum Dry Density (SPMDD). The imported fill should consist of granular material. An OPS Granular 'B' Type I will be suitable.

e) Curb and Gutter

- i) Typical concrete barrier curb with standard gutter will be as per OPSD 600.040.
- ii) Typical concrete semi-mountable curb with standard gutter will be as per OPSD 600.060.
- iii) Typical concrete curb will be as per OPSS 353 - Construction Specifications for Concrete Curb and Gutter Systems. All local and minor local streets will have concrete semi-mountable curb with standard gutter and all other streets will have concrete barrier curb with standard gutter unless otherwise approved by the Township.
- iv) Concrete shall be 30 MPa at 28 days with 7% _ 1.5% entrained air.
- v) Contraction joints shall be provided every 3.0 m.
- vi) Expansion joints shall be provided at both sides of catchbasins at the beginning and end of circular curves, at any abutting sidewalk, setbacks, gutter inlets, or any structure.

f) Radii of Curvature

The radii of curvature of the curbs and gutters at the intersections shall be as follows:

i) General

Arterial streets to:	Arterial streets	12.0m R
	Collector streets	12.0m R
	Local streets	12.0m R
Collector streets to:	Arterial streets	10.5m R
	Collector streets	9.0m R
	Local streets	9.0m R
Local streets to:	Arterial streets	7.5m R
	Collector streets	7.5m R
	Local streets	7.5m R

ii) Truck Routes

Collector streets to:	Collector streets	15.0m R
-----------------------	-------------------	---------

Note: a 3.0m daylighting triangle is required at the intersections itemized in ii) above.

Arterial streets to:	Arterial streets	15.0m R
	Collector streets	15.0m R
	Local streets	15.0m R

Note: a 6.0m daylighting triangle is required at the intersections itemized above.

iii) Cul-de-sac

The minimum required radii of curvature of curb and gutters for a residential and industrial cul-de-sac are as per ZSD 4 and ZSD 5.

g) Sidewalks

- i) Typical sidewalks shall be as per OPSD 310.010, 310.020, and 310.030. See ZSD 1A, ZSD 2, ZSD 6 and ZSD 7.
- ii) Typical concrete sidewalk will be as per OPSS 351 Construction Specification for Concrete Sidewalk.
- iii) Sidewalks shall be provided as follows:
 - Sidewalks are required on one side for local roads.
 - Sidewalks are required on both sides for collector and arterial roads.
 - Sidewalks may be required on:
 - a) one side of a minor - local road;
 - b) both sides of a local street if the street forms a walkway to a park, shopping area or schools.
 - Sidewalks may be required on one or both sides of cul-de-sacs. This will be reviewed on a case-by-case basis.
 - Sidewalks and fencing are required on all walkways as per ZSD 9.
- iv) Sidewalks shall be minimum of 1.5 m wide and shall be located as shown in and ZSD 6 and ZSD 7.
- v) Sidewalks and curbs shall be ramped at street intersections to permit easy passage of wheelchairs, etc. Ramps shall conform to OPSD 310.030.

- vi) Concrete shall be 30 MPa at 28 days with 7% _ 1.5% entrained air and not less than 355 Kg/m³ of cement. Maximum slump shall be 70 mm.
 - vii) Sidewalks are to be a minimum thickness of 100 mm.
 - viii) Concrete sidewalks in walkways shall be 125 mm thick.
 - ix) Driveways to industrial, commercial or multi-family properties shall be 150 mm thick.
 - x) All sidewalks to be constructed on a 100 mm minimum thick Granular 'A' bed.
 - xi) Expansion joints shall be provided every 6.0 m and where the sidewalk abuts a rigid object. Construction joints shall be provided every 1.5 m.
 - xii) Sidewalks shall have a 2% minimum and normal slope towards the road. Gradient in excess of 4% is subject to approval by the Township.
- h) Driveways
Driveways shall be as per ZSD 10.

1.6 Street Lighting

a) General

All subdivisions shall be provided with street lights in accordance with the standards in this section.

Proposed lighting layout, specifications, and details are subject to approval of the Township and the local hydro utility provider. For Subdivisions abutting collector or arterial roads, special lighting requirements and/or a photometric report may be required to evaluate the intensity of light. The Subdivider's Engineer shall review lighting requirements with the Township prior to final design.

Underground wiring shall be used for the electrical distribution system.

b) Design

- i) Street Lights shall be located in accordance with the Utility Location Drawing ZSD 1, ZSD 2 and ZSD 3.
- ii) All lighting systems shall meet the requirements of the current edition of the "Guide for the Design of Roadway Lighting" as published by the Roads and Transportation Association of Canada.
- iii) On streets with sidewalks on one side, light poles are to be located on the same side of the street as the sidewalk.

c) Installation

The installation of the electrical wiring, poles, lights and connections will be carried out by a Township approved Contractor and the cost of the materials and installation shall be borne by the Developer.

1.7 Signing and Markings

a) General

All new subdivision roadways or subdivision boundary roadways may require regulatory or warning signs or pavement markings and will require street name signs at various locations. All plans for signing shall be submitted for approval to the Township's Road Superintendent.

b) Design

- i) All regulatory signs shall be supplied and installed in accordance with the current edition (March, 2000) of the Ontario Traffic Manual - Book 5.
- ii) All warning signs shall be supplied and installed in accordance with the current edition (July, 2001) of the Ontario Traffic Manual - Book 6.
- iii) All pavement markings shall be supplied and placed in accordance with the current edition (March 2000) of the Ontario Traffic Manual - Book 11.
- iv) Street name signs are to be placed at every intersection and are to have double name plates. These signs are to be placed off the street lines in a location that will make the sign easily visible, to be approved by the Township's Road Superintendent.

c) Materials

- i) Regulatory and warning signs will be of the size and materials as outlined in the current editions of the Ontario Traffic Manual - Books 5 and 6.
- ii) Pavement markings shall be applied using durable products such as thermoplastics, two-component cold-reacted materials or tapes as outlined in the current edition of the Ontario Traffic Manual - Book 11.
- iii) Street name signs shall be 14 gauge steel minimum with white enameled 100mm letters in a green background. These plates are to be secured and mounted on 50mm diameter galvanized steel post, 3.5m long, driven 1.0m into the ground, or alternatively held in position by concrete placed at the bottom of the post.

d) Installation

All signing to be installed in accordance with the requirements of the most current editions of the Ontario Traffic Manual and as approved by the Township's Road Department.

SECTION 2 - STORM DRAINAGE

2.1 Storm Sewers

2.1.1 General

Storm sewers shall be designed in accordance with the design principles as outlined in the most current edition of the Ministry of the Environment Guidelines for the Design of Storm Sewers. Design computation sheets shall be submitted to the Township's Engineer for approval.

The basic design factors requiring evaluation are land use, design frequency, precipitation and runoff coefficient. The storm sewers shall be designed for a period of not less than 50 years and shall be designed to convey the 2-year minor storm event (unless otherwise required) to a sufficient outlet or to a storm water management facility which will control post-development peak flows to pre-development flows including the 2, 5, 25 and 100-year storm events.

The design of storm sewers shall be completed using the attached Rainfall Intensity Duration Curve, Drawing ZSD-16. Alternatively, the intensities may be calculated using the following formula for the Intensity-Duration-Frequency relationship and corresponding constants.

$$i = \frac{a}{(t+b)^c}$$

2 year

5 year

a	1114.83	477.211
b	8.716	2.475
c	0.8748	0.617

In addition, runoff from major storm events (i.e. 100-year and Regional Storms) shall be accommodated by an overland flow route that has been designed assuming that all of the source controls and storm water conveyance controls have failed.

2.1.2 Estimated Quantity of Storm Runoff

The Rational Formula is to be used to determine the quantity of storm water runoff. The use of other empirical runoff formulae must be approved by the Township's Engineer. The Rational Formula is: $Q = 2.78 C i A$

in which Q is the storm water runoff in liters per second (l/s), C is the runoff coefficient, i is the average rainfall intensity in mm per hour, and A is the drainage area tributary to the point under design in hectares.

In order to determine the intensity of rainfall for use in the Rational Formula, the following time of concentrations shall be used:

Flat residential districts (c<0.35)	20 minutes or less
Well developed districts	15 minutes or less
Densely developed districts (c>0.75)	10 minutes or less

The use of inlet times other than those indicated above, shall be subject to the approval of the Township's Engineer.

The following runoff coefficients are to be used with the Rational Formula:

Single Family Residential	0.35
Multi Family Residential	0.65
Undeveloped Residential	0.50

Commercial	0.70
Industrial	0.70
Parks, Cemetery, Playgrounds & Farmlands	0.20

In general, infiltration of ground water can be ignored in storm sewer design computations.

2.1.3 Location

Storm sewers shall be located in accordance with the Standard Utility Location Drawing ZSD 1, ZSD 2, and ZSD 3.

2.1.4 Minimum Pipe Size

The minimum size of the storm sewer shall be 250mm diameter. The sewer gradient shall be such that a minimum velocity of 0.9 m/s is attained with the maximum velocity being 4.6 m/s.

2.1.5 Cover

Minimum depth of cover on storm sewers to be 1.5m.

2.1.6 Hydraulic Calculations

Hydraulics - Gravity Sewers

The Mannings Formula shall be used to design gravity storm sewers.

The Manning Equation is expressed as:

$$V = \frac{1.49}{n} r^{2/3} S^{1/2}$$

where V is the velocity in metres per second

r is the hydraulic radius in metres

S is the slope of conduit

n is the roughness coefficient

'n' values for pipes flowing full shall be as follows:

0.013 - polyvinyl chloride (PVC) pipe

0.015 - concrete pipe 100 mm to 450 mm dia.

0.013 - all pipe larger than 450 mm dia.

2.1.7 Maintenance Hole Losses

Allowances for hydraulic losses in maintenance holes shall be as follows:

straight through flow - 0.025 m

22½° change in direction of flow - 0.035m

45° + change in direction of flow - 0.050 m

90° change in direction of flow - 0.075 m

Although the above invert drops will be adequate for sewers flowing at velocities at the low end of the acceptable range, the required drops should be calculated for high velocity sewers.

If the lateral inflow is a significant portion of the total flow through the manhole, then provision must be made for increased head loss. In such instances, a detailed hydraulic analysis of the head losses shall be submitted to the Township's Engineer.

2.2 Stormwater Management

2.2.1 General

Storm sewer systems shall include storm water management facilities and/or measures for both water quality and quantity in accordance with accepted practices as outlined in the most current edition of the publication entitled "Storm

water Management Planning and Design Manual" prepared for the Ontario Ministry of the Environment. Storm water storage requirements for quality control shall be in accordance with Table 3.1 of the above noted Manual with the "Level of Protection" being determined in consultation with the applicable Conservation Authority, the Department of Fisheries (DFO) and the Township's Engineer.

The design of individual stormwater management (SWM) facilities shall apply a 3-hour Chicago Rainfall Distribution using the Atmospheric Environmental Services (AES) intensity chart, ZSD-17. All storms provided (i.e. 2,5,25, and 100 year) shall be evaluated for quantity control purposes.

2.2.2 Quantity of Storm Water

a) Land Use

The Township's official land use plan shall be used to forecast the ultimate probable land use in any particular area. Consideration should be given to the effect of increased urbanization. Planning and development on a watershed or a sub-watershed basis is essential.

b) General

In the absence of watershed/sub-watershed planning, the following principles must be considered in determining water quantity criteria:

- (i) If there is a potential flood hazard immediately downstream of the subject site, water quantity control must be implemented;
- (ii) If the subject site is located in the headwater areas of the receiving watercourse, the post-development peak flow rates should be controlled to the pre-development levels; and
- (iii) If the subject site is located in the lower reaches of the watershed, either no quantity control will be required or

over-control will be required (if there are potential flooding concerns immediately downstream of the subject site).

Although the principles noted previously must be considered, the site specific characteristics will dictate the appropriate quantity control measures.

The use of computer software programs to determine and evaluate the storm water management facilities, runoff generated, etc. is acceptable provided the program is approved by the Township's Engineer. All design parameters and output are to be provided to the Township's Engineer by hard copy and on computer disc in a format acceptable to the Township's Engineer. In addition, a Certificate of Approval is required from the Ministry of the Environment prior to construction being undertaken.

2.3 Open Channels and Culverts

- a) The use of open channels shall not be permitted in residential or urbanized areas, however, existing or large open channels may be needed to be incorporated/analysed under certain circumstances. Open channel road drainage may be approved by the Township in rural or industrial areas.
- b) Open channels and culverts shall be designed to convey the 10 year storm under normal conditions. If the road profile warrants, the 25 year storm may be required. This design shall be completed using the attached Rainfall Intensity Duration Chart, Drawing ZSD-17.

The appropriate Design Storm shall be approved by the Township Engineer. In all cases, the 100 year storm event shall be contained in the open channels and adjacent riparian and buffer corridors. Flow over roads at culverts shall not exceed 300mm under this condition.

c) Thorough soils investigations and interpretations shall be a prerequisite to the detailed design of the open channel.

d) The Manning Formula shall be used in the design of open channels:

i) For grass-lined channels, 'n' values shall be based on the product of the velocity (V) and the hydraulic radius (r):

$V \times r$	n
<0.5	0.150
0.5 to 1.0	0.120
1.0 to 2.0	0.070
2.0 to 5.0	0.050
5.0 to 10.0	0.035
>10.0	0.030

ii) Side slopes for grass-lined channels shall not be steeper than 3H:IV.

iii) Flow velocities shall be in the following ranges:

- sand, sandy loam, or silty loam

0.75 m/s to 0.90 m/s

- gravel, or clay material

0.75 m/s to 1.50 m/s

e) Full details of open channel design including energy dissipation structures shall be submitted to the Township's Engineer.

f) To carry open channel drainage under driveways and across intersections, a 300 mm dia. minimum culvert shall be used. It may be

necessary to increase the culvert size to accommodate higher flows from upstream tributary areas.

- g) Culverts shall be 1.6 mm thick minimum galvanized corrugated steel pipe or approved equal. This material shall conform to the requirements of CSA Standard CAN 3- G401-M81 - Corrugated Steel Pipe Products.

2.4 Pipe Materials

Pipe material shall be concrete, polyvinyl chloride (PVC), or high density polyethylene (HDPE).

Pipe sub-drains to be corrugated steel pipe or polyvinyl chloride (PVC) pipe.

- i) Concrete Pipe
shall conform to CSA and ASTM Standards manufactured in accordance with the following specifications:
- a) Non-Reinforced to CAN/CSA A257.1 (100mm - 600mm dia.)
 - b) Reinforced to CAN/CSA 257.2
- ii) Polyvinyl Chloride (PVC) Pipe - smooth wall (100mm - 600mm inclusive)
shall be certified to CSA B182.1 and CSA B182.2 and conform to ASTM D3034. Pipe sizes 200 mm diameter and larger shall be SDR 35, and less than 200 mm diameter shall be SDR 28 for private drain connections (PDC).
- iii) Ribbed Polyvinyl Chloride (PVC) Pipe (200mm - 600mm inclusive)
shall be certified to CSA B182.4 and meet the requirements of ASTM F794.
- iv) High Density Polyethylene (HDPE) Pipe (200mm-600mm inclusive),

for use on storm sewers only, with integral bell and spigot, shall be certified to CSA B182.6.

2.4.1 Pipe Joints

i) Concrete Pipe

All joints shall be rubber gasket conforming to CSA A257.3 and ASTM C443M-94.

ii) PVC Pipe

Sealing gaskets shall meet the requirements of CSA B182.2 and ASTM F477.

All PVC fabricated and moulded fittings shall be CSA certified.

iii) HDPE Pipe

All HDPE fabricated pipe and moulded fittings shall be CSA certified.

2.5 Maintenance Holes

a) Maintenance Holes shall be located at the junctions of sewers and at changes in grade, alignment or diameter. Maintenance Holes shall be precast concrete conforming to OPSD - 701.010 to 701.080.

b) Manhole frames and grates to be in accordance with OPSD 401.010 (Type A).

- c) The precast concrete adjustment units used to extend maintenance holes and catchbasins shall be in accordance with OPSD 704.010 and OPSS 408. Three courses, minimum, of approved adjustment units are required on precast maintenance holes. The outside and interior faces of all concrete rings should be plastered and trowelled smooth with mortar 6mm thick, consisting of one part masonry cement and 3 parts sand.
- d) Maintenance hole steps shall be circular or rectangular aluminum and shall be in accordance with OPSD 405.010 or OPSD 405.020. Steps to be at 300mm centres vertically with 450mm maximum distance from top of maintenance hole to the first step.
- e) Aluminum safety landings shall be provided in maintenance holes deeper than 5.0 m from the top of maintenance hole cover to the lowest invert. Details shall be in accordance with OPSD 404.020.
- f) All precast maintenance hole section joints shall contain an approved rubber gasket or approved equal. Joints, lifting holes and pipe connections are to be filled with a non-shrink mortar mix.
- g) Drop structures are required at maintenance holes where the difference in invert elevations is greater than 900mm for storm sewers and shall be in accordance with OPSD 1003.010 or OPSD 1003.020. Internal drop structures are an acceptable alternative, when connecting to existing manholes and shall be according to OPSD 1003.030 and 1003.031.
- h) Benching of manholes is to be performed in accordance with OPSD 701.021.

- i) A flexible joint shall be provided on all pipes, within 0.3 m of the outside wall of the maintenance hole. Concrete bedding 20 MPa to solid ground and extending to the first pipe joint may be used as an alternate approach.
- j) All maintenance holes installed must be a “boot type” KOR-N-SEAL style available from Centennial Concrete Pipe and Products, or an approved equal.
- k) Maintenance hole spacing shall be as follows:

<u>Pipe Size</u>	<u>Maximum</u> <u>Maintenance Hole Spacing</u>
Up to 450 mm	120 m
525 mm to 750 mm	150 m
over 750 mm	180 m
- l) Precast Maintenance hole tees may be used in storm sewers 1200 mm in diameter and over. The precast riser sections shall be at least 1200 mm in diameter. Maintenance hole tees shall be bedded on 28 MPa concrete. Full details shall be submitted to the Township's Engineer for approval.

2.6 Catch Basins

- a) Catch basins shall conform to OPSD 705.010, 705.020 and 705.030.
- b) Catch basin leads shall not be less than 200 mm in diameter and shall connect to the storm sewer as shown in OPSD 708.01 or OPSD 708.03.
- c) Catch basin frames and grates shall conform to the details in OPSD 400.020 and must meet ASTM Designation A-48. Catch basin frames with curb inlet overflow, OPSD 400.090, shall be used for arterial roads and at all low points in the road. Ditch inlet catchbasin grate shall

conform to OPSD 403.010. Curb inlet catch basin to be in accordance with ZSD-19.

- d) Curb inlet catch basins shall be provided at all low points in the road with single inlet catch basins at intersections. Additional catch basins shall also be provided as follows:

<u>Road Gradient (%)</u>	<u>Maximum Spacing</u>
0.5 to 3.0	90 m
3.1 to 4.5	75 m
greater than 4.6	60 m

- e) The precast concrete adjustments units used to extend maintenance hole and catch basins shall meet the OPSD 704.010 and OPSS 407. Three courses, minimum, of approved adjustment units are required on precast maintenance holes. The outside and interior faces of all concrete rings shall be plastered and trowelled smooth with mortar 6mm thick, consisting of 1 part masonry cement and 3 parts sand.
- f) All joints, lifting holes, and pipe connections are to be filled with a non-shrink mortar mix.

2.7 Installation

- a) Sewer pipe bedding shall conform to the Township's bedding standards for gravity and pressure pipe and shall be in accordance with ZSD 11 and ZSD 12.
- b) Approved excavated material may be used for backfill under roads, sidewalks and driveways where an independent soils investigation, carried out by a Geotechnical Engineer, indicates that this is practical. Compacting of the material shall be carried out in accordance with the recommendations of the Geotechnical Engineer.

If the excavated material is unsuitable, the trench shall be backfilled with Granular 'B' material conforming to OPSS 1010 and compacted to 95 percent Standard Proctor Density.

- c) Sewer service connections for rigid main pipe sewer shall be in accordance with OPSD 1006.010 and for flexible main pipe sewer shall be in accordance with OPSD 1006.020. A 50mm x 100mm timber marker stake shall be installed at the end of the private service connection from the invert to 300mm above finished ground. The stake shall be painted brown.
- d) All installations shall be subject to the inspection, approval and acceptance of the Township.
- e) If any utilities or services are encountered during construction they are to be supported in accordance with the requirements of the various utility companies as applicable.
- f) Road surfaces shall be restored to its original condition where existing roads are disturbed, all to the satisfaction of the Township.
- g) All new sewers shall be inspected by means of a closed circuit television inspection in accordance with OPSS 409 and one copy of the video given to the Township for its records. This work shall be performed by an independent inspection company under the supervision of the Township and paid for by the Contractor.
- h) Ring deflection testing shall be performed on all new pipe sewers constructed using plastic pipe in accordance with OPSS 410.07.15.05. Testing is to take place no sooner than 30 days after the completion of backfilling and installation of service connections and again just prior to the end of warranty.

2.8 Private Drain Connections

Refer to Section 5.1.

SECTION 3 - SANITARY SEWERS

SECTION 4 - WATERMAINS

SECTION 5 - LOT SERVICING AND LOT GRADING

5.1 Lot Servicing

a) General

The servicing of all lots is to be in accordance with the standards set out in this section. Before any work is to commence in the Township's right-of-way, approval must be given by the Township and County Engineer.

b) Sanitary Private Drain Connections

refer to Section 3 - Sanitary Sewers

c) Storm Private Drain Connections

- i) Pipe materials shall conform to Section 3.
- ii) If directed by the Township's Engineer, each property will be provided with a private drain connection of a minimum diameter of 100 mm having a minimum slope of 2%, as per ZSD-18.
- iii) Private drain connections to industrial, commercial or high density residential properties shall not be less than 150 mm diameter with an inspection manhole placed at the property line just onto private property.
- iv) ZSD 15 shows the orientation of the private drain connections.
- v) Roof water leaders shall not be directly connected to the storm sewers. Direct connection of foundation weeping tiles to the storm

sewer is prohibited. Weeping tiles may be pumped above the foundation elevation prior to connection into the storm PDC.

- vi) The installation of the private drain connections shall meet the standards set out in Section 2.7.

- d) Water Services

Refer to Section 4 - Watermains.

- e) Utilities
 - i) All other utilities are to be installed in accordance with the standards of the utility company.
 - ii) Refer to ZSD 15 for the location of required services and utilities.

- f) Driveways
 - i) All driveways shall meet the requirements shown in ZSD 10.
 - ii) Driveways are to be designed and installed perpendicular to the roadway.
 - iii) No part of the driveway shall encroach upon the property boundaries when extended from the edge of the right-of-way to the roadway.

- iv) If a concrete driveway is installed, expansion joints are to be installed at the property line, at both sides of the sidewalk and at the curb.

5.2 Lot Grading

a) General

All subdivisions shall be graded in accordance with these specifications and the details shown on ZSD 13. Lot grading plans shall be prepared by the developer and approved by the Township along with the subdivision servicing drawings.

Existing elevations and grading details to be shown shall include sufficient area of adjacent lands to define total drainage patterns.

b) Lot Grading Specifications

- i) Yard surfaces shall have a minimum slope of 2% (in special cases 1% to be approved by the Township's Engineer).
- ii) Drainage flows shall be directed away from foundations.
- iii) Drainage flows which are carried around houses are to be confined in defined swales located as far from the houses as possible.
- iv) The desirable sideyard swale depth is to be 225 mm. The minimum allowable depth shall be 150 mm. The maximum swale depth is to be variable, but dependent on location and safety considerations.

- v) The minimum major/rear yard swale depth is to be 300mm, located a minimum 1.5m from rear property line with minimum 4H:1V slope.

- vi) Grades:
 - a) Minor swales - provides drainage for up to four lots
 - the minimum grade shall be 2% (special cases 1% to be approved by the Township).

 - b) Major/rear yard swales - provide drainage for more than four lots
 - the minimum grade shall be 1%.

- vii) The maximum flow allowable in a side yard swale shall be that from four back yards.

- viii) The maximum flow in a rear yard swale shall be that from 15 back yards, depending on lot size and grade. The maximum length of a rear yard swale to a catchbasin shall be 80 m. The maximum area contributing to the rear yard swale shall be 1.0 ha. The maximum flow in a rear yard swale which is discharged directly onto the road allowance, is that from six backyards.

- ix) Where possible, it is preferred to have lots drain to the front of the property, rather than to a rear yard catchbasin.

- x) No front yard catchbasins shall be allowed.

- xi) Maximum allowable ponding at gutters on roads is 300mm.

- xii) Ground elevations at buildings shall be 225mm above any adjacent downstream overland flow routes.

- xiii) The maximum ponding permitted at rear yards catchbasins is 450mm.

SECTION 6 - DRAWINGS

6.1 General

All contract drawings are to be on the Township's Standard drawing size, metric designation A1 which is 594mm x 841mm. The Township's Standard title block is to be used and placed in the lower right hand corner of the sheet. All drawings are to be signed and sealed by a Professional Engineer at the location provided in the title block.

6.2 Drawing Standards

All drawings must meet the following standards:

- a) Existing conditions are to be drawn with a lighter pen than the proposed construction.
- b) North shall be shown on all drawings to the top or to the right.
- c) All elevations shall be to Geodetic Survey of Canada Datum.
- d) The zero chainage shall start at the projection of an intersecting street's center line. Chainages shall be indicated at 25m stations. Where possible, the profile must be a vertical projection of the plan. Calculated chainages of the beginning and ending of horizontal or vertical curves must be noted on the plan and profile.
- e) A legend shall be used to indicate services as shown in ZSD 14.
- f) All revisions to original drawings must be recorded in a revision block and dated.

6.3 Drawings to be Submitted

The following drawings are to be submitted when applicable.

(3 complete sets.)

1) Cover Sheet

The cover sheet shall indicate the following:

- a) A list of drawings included in the Contract Set.
- b) A Key Plan showing the location of the proposed development (scale 1:1000)
- c) The project title and the name and address of the Owner and the Contractor

2) Master Plan - Services to be constructed

A drawing showing all services to be constructed using a scale of 1:1000.

3) Lot Grading Plans

The lot grading plan shall meet the following requirements:

- a) Indicate north by an arrow on the plan.
- b) Basic Plan:
 - scale 1:500;
 - showing all existing and proposed lot numbers;
 - show all street names;
 - show all lot frontages;
 - show all sidewalks to be constructed by the subdivider;
 - indicate all lots that are semi-detached (SD) or back split (BS).
- c) Elevations that are to be shown on the Grading Plan include:
 - all elevations are to be Geodetic;

- final ground elevations at lot corners and house corners;
- final centre line of road elevation every 25 m;
- existing ground elevations are to be shown by means of spot elevations and contours.

These contours shall extend a minimum of 25 m beyond the limit of the plan;

- for single lot applications, the difference between the building sill elevation and the centre road elevation shall be shown. The rear lot difference to sill elevation shall also be shown.

d) Drainage Information

- show the location and direction of flows of swales by means of arrows. At least one arrow is to be shown at the rear of each lot;
- show all proposed rear lot catchbasins, leads and easements.
- show the location and direction of swales by means of wavy arrows.
- show the location and direction of overland flow routes by means of bold arrows.

See Drawing ZSD-14 for typical arrows.

4) General Plan - Sanitary Sewer System

A drawing showing the Sanitary Sewerage System and Areas to a scale of 1:1000, including Sanitary Design Sheet.

5) General Plan - Storm Drainage System

A general plan to a scale of 1:1000 showing the Storm Drainage System and Drainage Areas, including Storm Design Sheet.

6) General Plan - Water Distribution System

A drawing showing the existing and proposed water distribution system to a scale of 1:1000.

7) General Plan - Street Lighting

A general plan to a scale of 1:1000 showing the proposed street lighting layout.

8) Plan and Profile

A plan and profile drawing for each street in the subdivision and all rear yard catchbasins. These drawings shall include all pertinent information as deemed necessary by the Township's Engineer. The location and brief description of soil investigations shall be shown on the plan and profile drawings. (Boreholes)

Scale - Horizontal	1:500
Vertical	1:50

9) Detailed Drawings

The detailed drawings shall include all details necessary for the proper construction of the works. It will be the Developer's responsibility to ensure that the Contractor is provided with the miscellaneous details included in these Servicing Standards and other various details for the completion of the project.

6.4 "As-Constructed" Drawings

On completion of the project, the drawings must be revised to show the services as they were actually constructed. The completed works shall be on a CD and must be of a quality acceptable to the Township's Engineer.

The Township shall be provided with one CD and two sets of prints of all the “as-constructed” drawings used for the project.

The following details shall be shown on the Contract Drawings and shall be amended to indicate the “as-constructed” locations of all services:

- street names;
- registered plan numbers, lot numbers, and/or Township number, lot lines, street lines, frontages, and easements;
- ties to property bars for all water services (0.30m accuracy);
- the chainage of private drain connections measured from the nearest downstream manhole (0.30m accuracy);
- the location and elevation shown on the profile of all services encountered while undertaking the work (0.30m location accuracy, 0.02m elevation accuracy);
- the location on plan of all services (0.50m accuracy);
- center line road profile (25m minimum intervals);
- the full details for all services i.e. sizes, grades, materials, elevations, etc.

INDEX

SECTION 1	ROADS
SECTION 2	STORM DRAINAGE
SECTION 3	SANITARY SEWERS
SECTION 4	WATERMAINS
SECTION 5	LOT SERVICING AND LOT GRADING
SECTION 6	DRAWINGS

TABLE OF CONTENTS

Page No.

GENERAL REQUIREMENTS

SECTION 1 - ROADS

1.1 General	3
1.2 Street Classification	3
1.3 Road Allowance, Pavement Widths, Location and Layout	4
1.4 Grades	5
1.5 Design and Construction	5
1.6 Street Lighting	12
1.7 Signing and Markings	13

SECTION 2 - STORM SEWERS/STORMWATER MANAGEMENT

2.1 Storm Sewers	15
2.2 Storm Water Management	18
2.3 Open Channels and Culverts	20
2.4 Pipe Materials	22
2.5 Maintenance Holes	23
2.6 Catch Basins	25
2.7 Installation	26
2.8 Private Drain Connections	27

SECTION 3 - SANITARY SEWERS

SECTION 4 - WATERMAINS

SECTION 5 - LOT SERVICING AND LOT GRADING

5.1 Lot Servicing	30
5.2 Lot Grading	32

SECTION 6 - DRAWINGS

6.1 General	34
6.2 Drawing Standards	34
6.3 Drawings to be Submitted	35
6.4 "As-Constructed" Drawings	37

LIST OF STANDARDS

<u>Zorra</u> <u>Standard Drawing</u>	<u>Description</u>
ZSD-1	Utility Locations for Residential Roads - 20.1m Road Allowance
ZSD-2	Utility Locations for Residential Roads - 26.1m Road Allowance
ZSD-3	Utility Locations for Industrial Roads - 26.1m Road Allowance
ZSD-4	Residential Cul-de-sac
ZSD-5	Industrial Cul-de-sac
ZSD-6	Standard Cross-Section - Local and Minor-Local Roadway Residential
ZSD-7	Standard Cross-Section - Collector/Arterial Roadway Residential
ZSD-8	Standard Cross-Section - Industrial Roadway
ZSD-9	Walkway Details
ZSD-10	Residential Driveway Entrance
ZSD-11	Pipe Bedding Details Class B and Class C
ZSD-12	Pipe Bedding Details Class A-1 and Class A-2
ZSD-13	Lot Drainage Plan
ZSD-14	Plan and Profile Legend
ZSD-15	Lot Servicing
ZSD-16	Rainfall Intensity Duration Curves
ZSD-17	SWM Rainfall Intensity Chart
ZSD-18	Private Drain Connections at Street Line
ZSD-19	600 x 840 Precast Concrete Curb Inlet Catchbasin

<u>OPSD Standard No.</u>	<u>Description</u>
216.010	Boulevard Treatments, Urban Section
310.010	Concrete Sidewalk
310.030	Concrete Sidewalk Ramps at Intersections
400.020	Cast Iron, Square Frame with Square Flat Grate for Catchbasins
400.090	Cast Iron, Curb Inlet Overflow for Catchbasins
401.010	Cast Iron, Square Frame with Circular Closed or Open Cover for Maintenance Holes
403.010	Galvanized Steel Honeycomb Grating for Ditch Inlet
404.020	Aluminum Safety Platform for Circular Maintenance Hole
405.010	Maintenance Hole Steps (Hollow)
405.020	Maintenance Hole Steps (Solid)
600.040	Concrete Barrier Curb with Standard Gutter
600.060	Concrete Semi-Mountable Curb with Standard Gutter
701.010	Precast Maintenance Hole (1200mm dia.)
701.011	Precast Maintenance Hole (1500mm dia.)
701.012	Precast Maintenance Hole (1800mm dia.)
701.013	Precast Maintenance Hole (2400mm dia.)
701.014	Precast Maintenance Hole (3000mm dia.)
701.015	Precast Maintenance Hole (3600mm dia.)
701.021	Maintenance Hole Benching and Pipe Opening Details
701.030	Precast Concrete Maintenance Hole Components (1200mm dia.)
701.040	Precast Concrete Maintenance Hole Components (1500mm dia.)
701.050	Precast Concrete Maintenance Hole Components (1800mm dia.)
701.060	Precast Concrete Maintenance Hole Components (2400mm dia.)
701.070	Precast Concrete Maintenance Hole Components (3000mm dia.)
701.080	Precast Concrete Maintenance Hole Components (3600mm dia.)
704.010	Maintenance Hole and Catchbasin Precast Concrete Adjustment Units
705.010	Precast Concrete Catchbasin 600mm x 600mm
705.020	Precast Concrete Twin Inlet Catchbasin 600mm x 1450mm
705.030	Precast Concrete Ditch Inlet 600mm x 600mm
707.010	Precast Concrete Maintenance Hole Tee
708.010	Catchbasin Connection for Rigid Main Pipe Sewer
708.030	Catchbasin Connection for Flexible Main Pipe Sewer
1003.010	Cast-in-Place Maintenance Hole Drop Structure Tee
1003.020	Cast-in-Place Maintenance Hope Drop Structure Wye
1003.030	Internal Drop Structure for Existing Maintenance Hole
1003.031	Internal Drop Structure for New Maintenance Hole
1006.010	Sewer Service Connections for Rigid Main Pipe Sewer
1006.020	Sewer Service Connections for Flexible Main Pipe Sewer

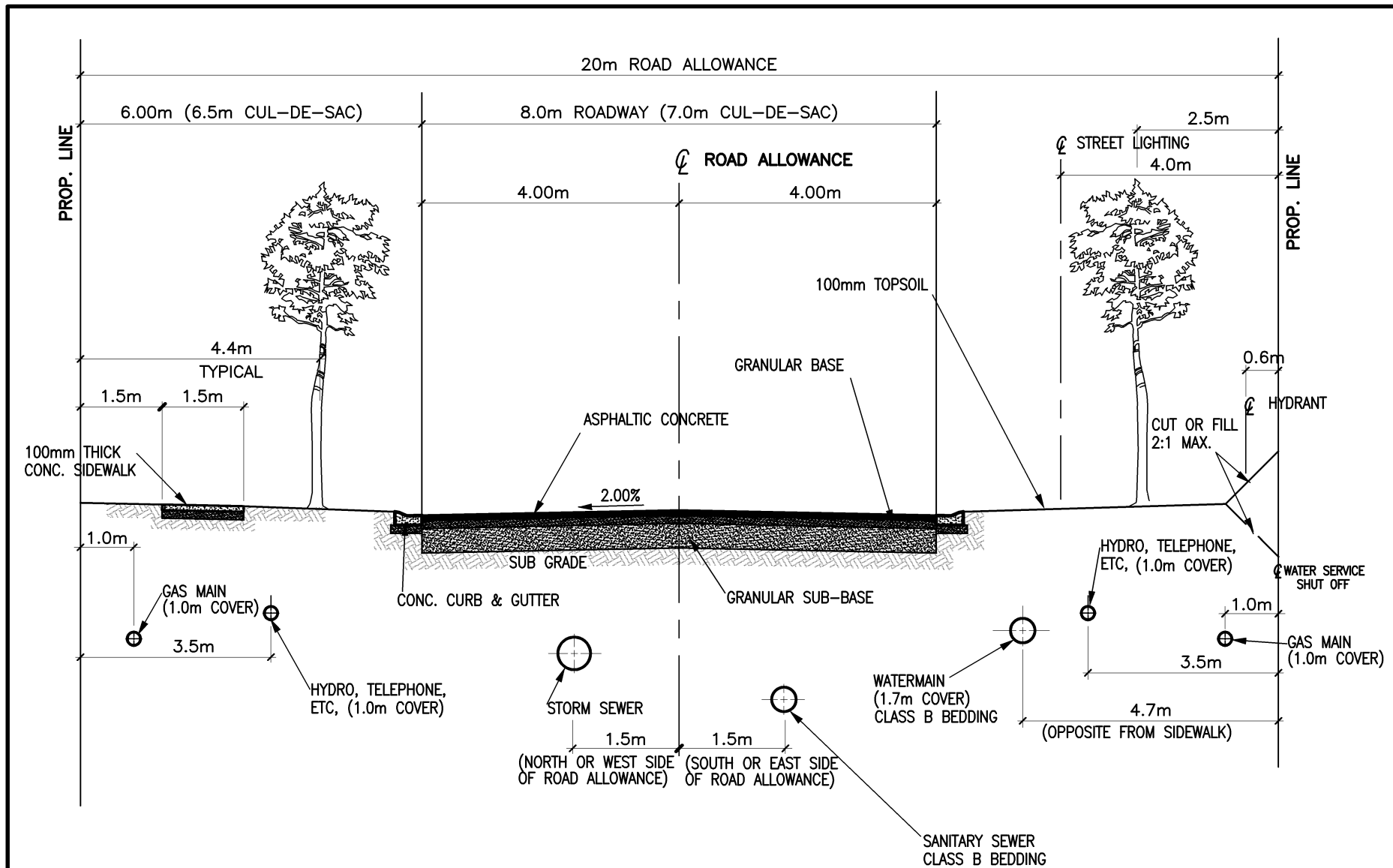

NOTES:

1. HYDRO & STREET LIGHTING WIRING TO BE UNDERGROUND. BELL, HYDRO, & T.V. CABLE MAY BE STACKED IN A COMMON TRENCH.
2. BELL & T.V. CABLE PEDESTALS ARE TO BE LOCATED AT 0.3m(1') OFF PROPERTY LINE.
3. WHERE POSSIBLE, LOCATE STREET LIGHTS, HYDRANTS, PEDESTALS, ETC. OPPOSITE PERPENDICULAR LOT LINES.
4. STREET LIGHTING TO BE OPPOSITE SIDE OF ROAD FROM SIDEWALK WITH TREE OFFSETS TO MATCH.

TOWNSHIP OF ZORRA	
UTILITY LOCATIONS	
FOR	
RESIDENTIAL ROADS	
20.0m ROAD ALLOWANCE	
MARCH, 2005/REV.	ZSD - 1

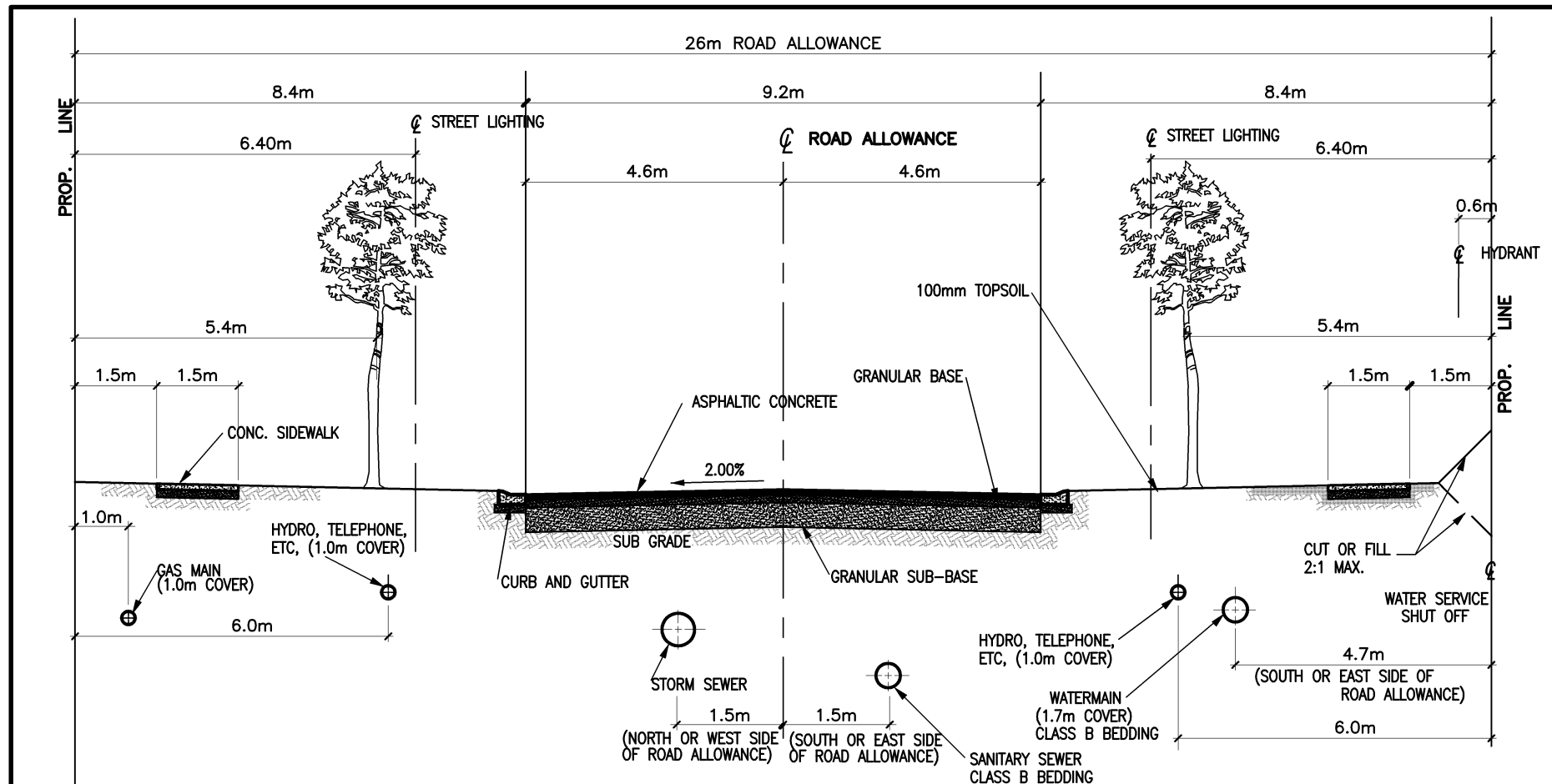

STANDARD RIGHT-OF-WAY CROSS-SECTION
FOR COLLECTOR STREETS WITH
CONCRETE CURB AND GUTTER AND ASPHALTIC CONCRETE

NOTES:

1. HYDRO & STREET LIGHTING WIRING TO BE UNDERGROUND. BELL, HYDRO, & T.V. CABLE MAY BE STACKED IN A COMMON TRENCH.
2. BELL & T.V. CABLE PEDESTALS ARE TO BE LOCATED AT 0.3m(1') OFF PROPERTY LINE.
3. WHERE POSSIBLE, LOCATE STREET LIGHTS, HYDRANTS, PEDESTALS, ETC. OPPOSITE PERPENDICULAR LOT LINES.

TOWNSHIP OF ZORRA	
UTILITY LOCATIONS	
FOR	
RESIDENTIAL ROADS	
26.0m ROAD ALLOWANCE	
MARCH,2005/REV.	ZSD - 2

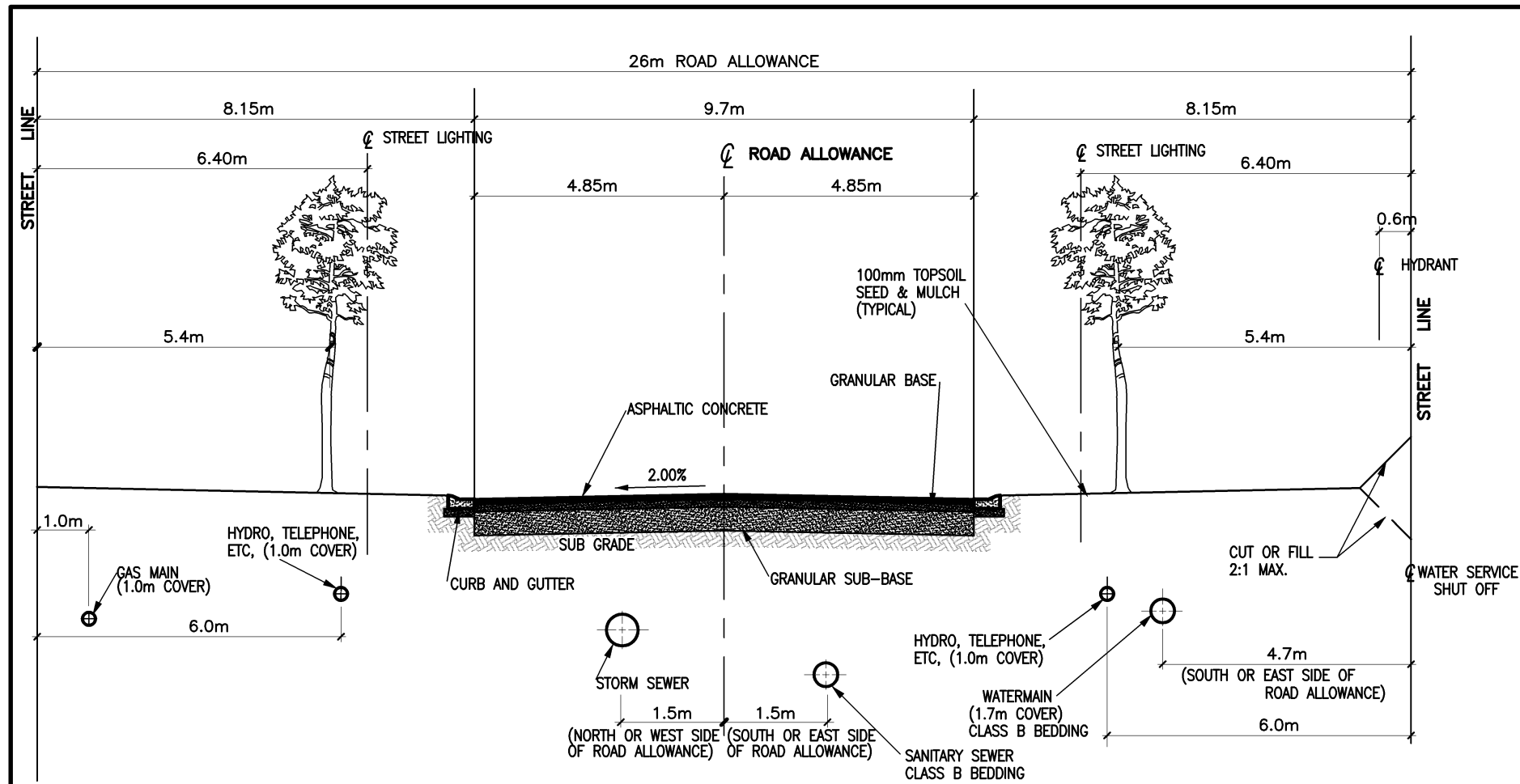

STANDARD RIGHT-OF-WAY CROSS-SECTION
FOR COLLECTOR STREETS WITH
CONCRETE CURB AND GUTTER AND ASPHALTIC CONCRETE

NOTES:

1. HYDRO & STREET LIGHTING WIRING TO BE UNDERGROUND. BELL, HYDRO, & T.V. CABLE MAY BE STACKED IN A COMMON TRENCH.
2. BELL & T.V. CABLE PEDESTALS ARE TO BE LOCATED AT 0.3m(1') OFF PROPERTY LINE.
3. WHERE POSSIBLE, LOCATE STREET LIGHTS, HYDRANTS, PEDESTALS, ETC. OPPOSITE PERPENDICULAR LOT LINES.

TOWNSHIP OF ZORRA	
UTILITY LOCATIONS	
FOR	
INDUSTRIAL ROADS	
26.0m ROAD ALLOWANCE	
MARCH,2005/REV.	ZSD - 3

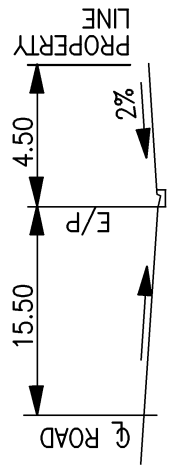
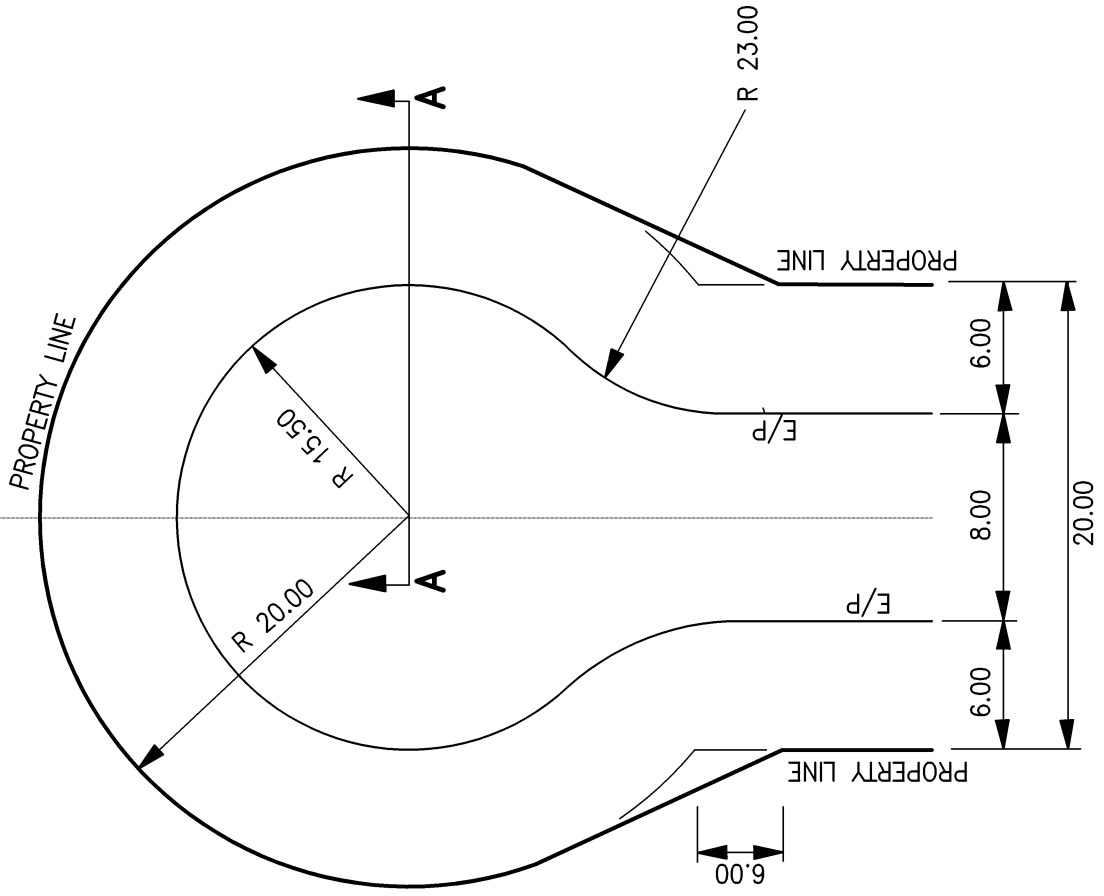

SECTION A-A

NOTES:

1. ALL DIMENSIONS IN METRES UNLESS SHOWN OTHERWISE
2. A 1.50 m WIDE SIDEWALK SHALL BE INSTALLED IF DIRECTED BY THE TOWNSHIP.
3. CURB AND GUTTER PER OPSD-600.060

TOWNSHIP OF ZORRA

**RESIDENTIAL
CUL-DE-SAC**

MARCH, 2005 / REV.

ZSD - 4

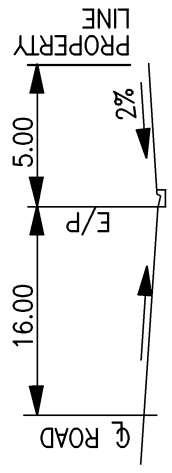
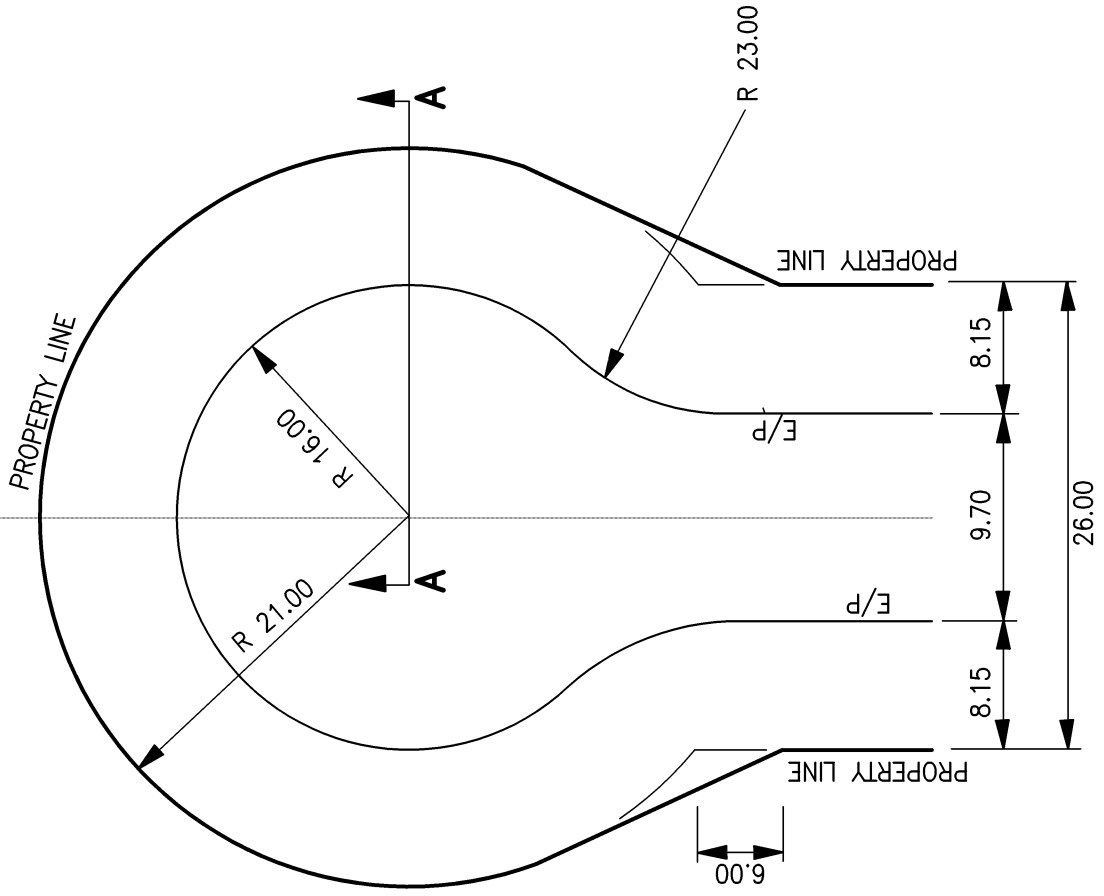

SECTION A-A

NOTES:

- 1. ALL DIMENSIONS IN METRES UNLESS SHOWN OTHERWISE
- 2. CURB AND GUTTER PER OPSD-600.040

TOWNSHIP OF ZORRA	
INDUSTRIAL CUL-DE-SAC	
MARCH, 2005 / REV.	ZSD - 5

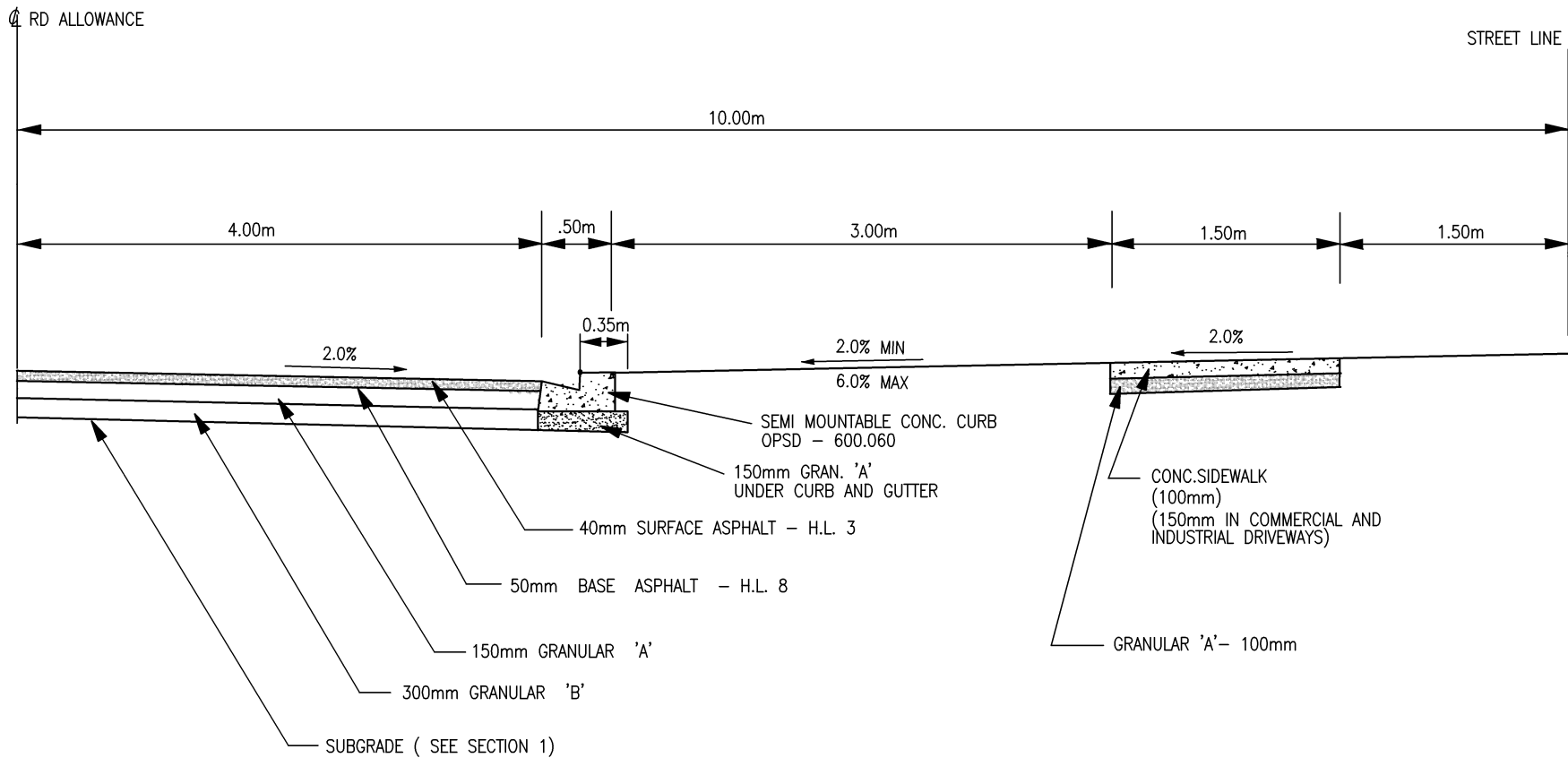

NOTES:

- 1 - SEE SERVICING STANDARDS - SECTION 1.
- 2 - CROWN OF ROAD TO BE 2%.
- 3 - 2% OF CROSSFALL TO BE USED IN SIDEWALK CONSTRUCTION.
- 4 - CONCRETE FOR CURBS AND SIDEWALKS TO BE 30 mpa AT 28 DAYS.
- 5 - ALL ASPHALT TO BE COMPACTED TO 97% MARSHALL DENSITY.
- 6 - ALL GRANULAR MATERIALS TO BE COMPACTED TO 100% S.P.M.D.D.

TOWNSHIP OF ZORRA	
LOCAL AND MINOR-LOCAL ROADWAY RESIDENTIAL	
20.0m ROAD ALLOWANCE	
MARCH, 2005/REV.	ZSD - 6

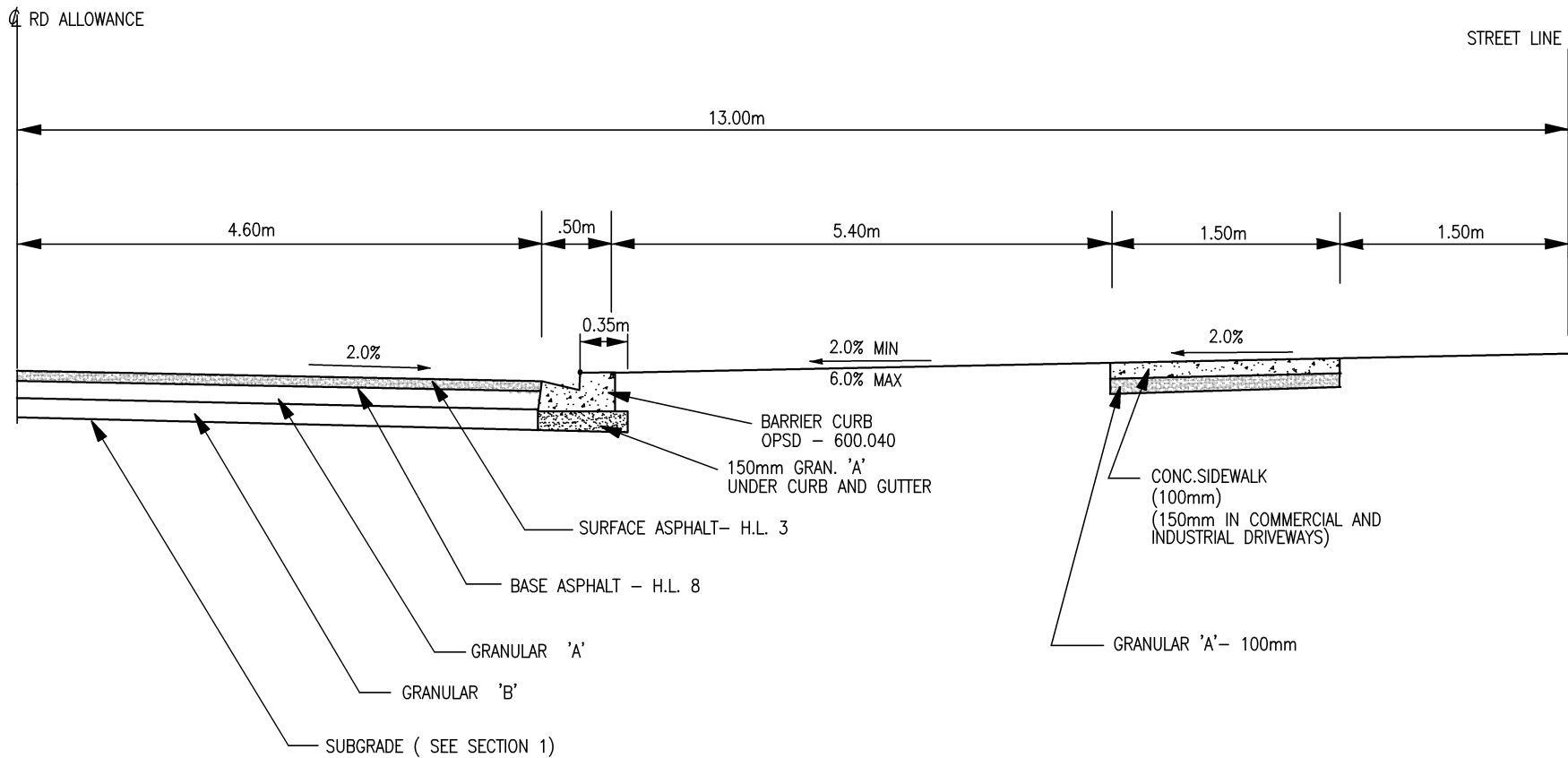

NOTES:

- 1 - SEE SERVICING STANDARDS - SECTION 1.
- 2 - CROWN OF ROAD TO BE 2%.
- 3 - 2% OF CROSSFALL TO BE USED IN SIDEWALK CONSTRUCTION.
- 4 - CONCRETE FOR CURBS AND SIDEWALKS TO BE 30 mpa AT 28 DAYS.
- 5 - ALL ASPHALT TO BE COMPACTED TO 97% MARSHALL DENSITY.
- 6 - ALL GRANULAR MATERIALS TO BE COMPACTED TO 100% S.P.M.D.D.

TOWNSHIP OF ZORRA	
COLLECTOR / ARTERIAL ROADWAY RESIDENTIAL	
26.0m ROAD ALLOWANCE	
MARCH,2005/REV.	ZSD - 7

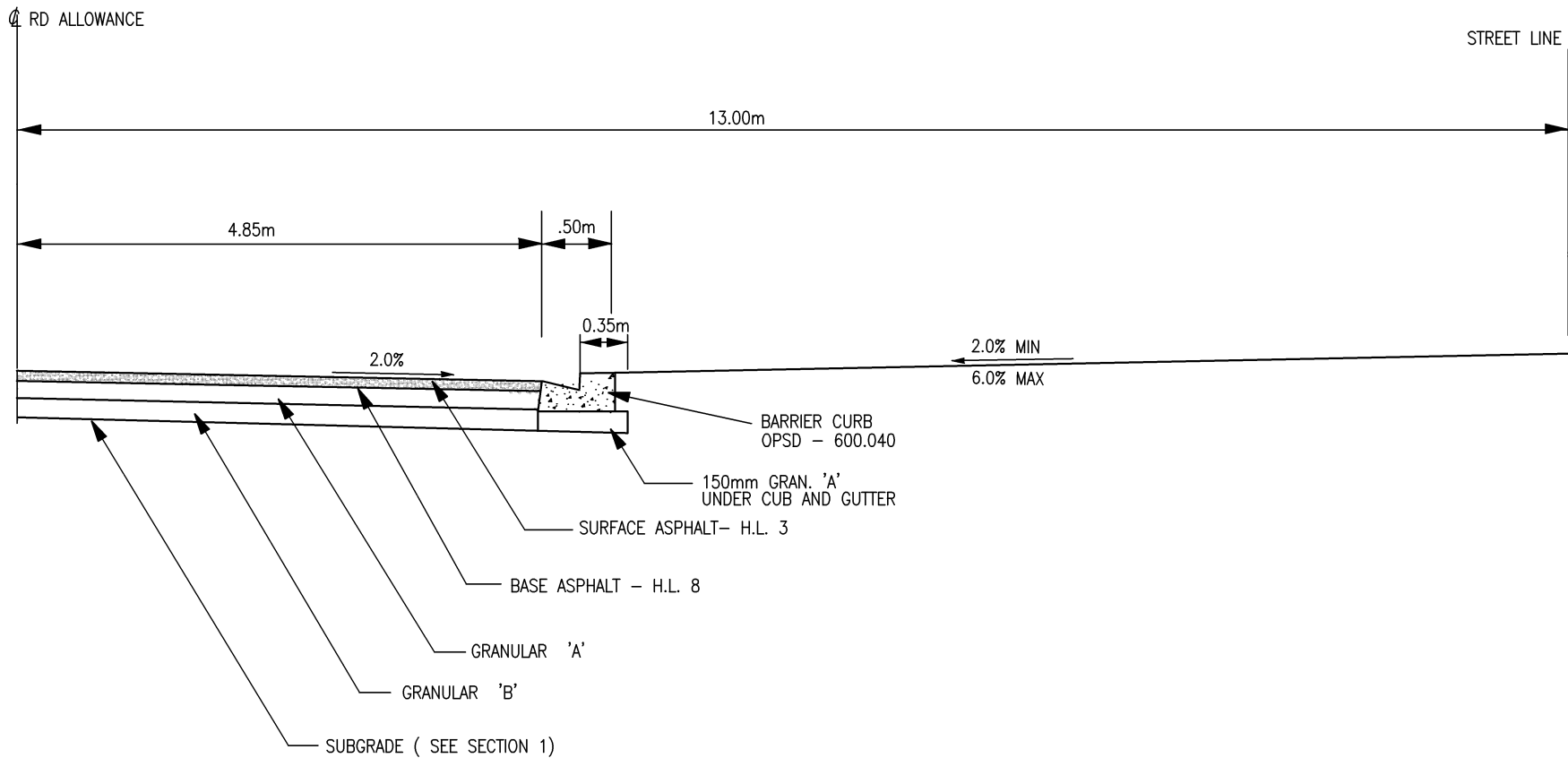

NOTES:

- 1 - SEE SERVICING STANDARDS - SECTION 1.
- 2 - CROWN OF ROAD TO BE 2%.
- 3 - 2% OF CROSSFALL TO BE USED IN SIDEWALK CONSTRUCTION.
- 4 - CONCRETE FOR CURBS AND SIDEWALKS TO BE 30 mpa AT 28 DAYS.
- 5 - ALL ASPHALT TO BE COMPACTED TO 97% MARSHALL DENSITY.
- 6 - ALL GRANULAR MATERIALS TO BE COMPACTED TO 100% S.P.M.D.D.

TOWNSHIP OF ZORRA	
INDUSTRIAL ROADWAY 26.0m ROAD ALLOWANCE	
MARCH, 2005/REV.	MSD - 8

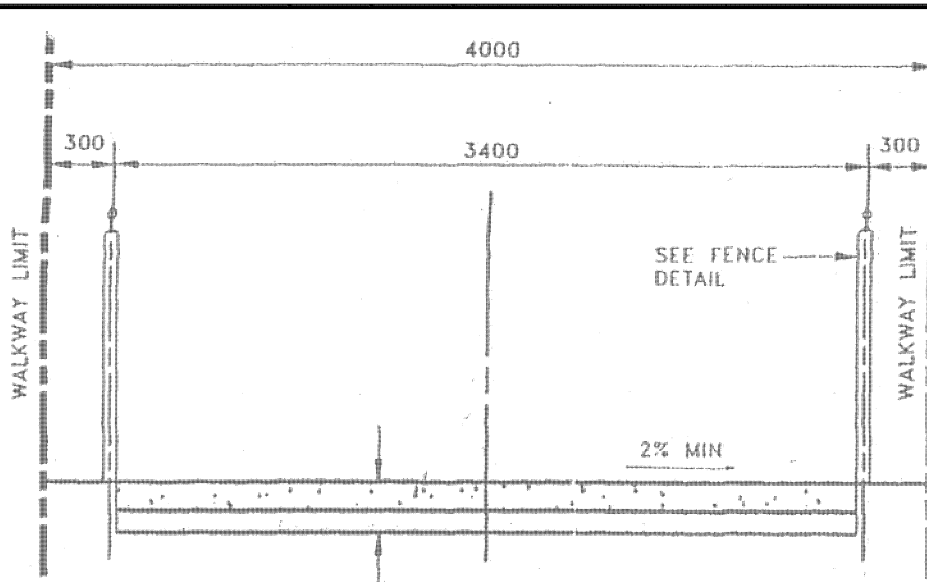

125 CONCRETE - 30 MPa
100 COMPACTED GRANULAR 'A'

CROSS SECTION

END, CORNER, STRAINING OR GATE POST LINE POST

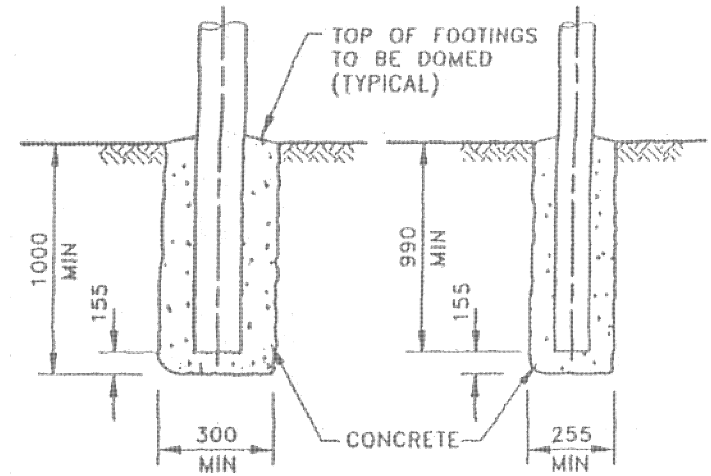

FOOTING DETAIL

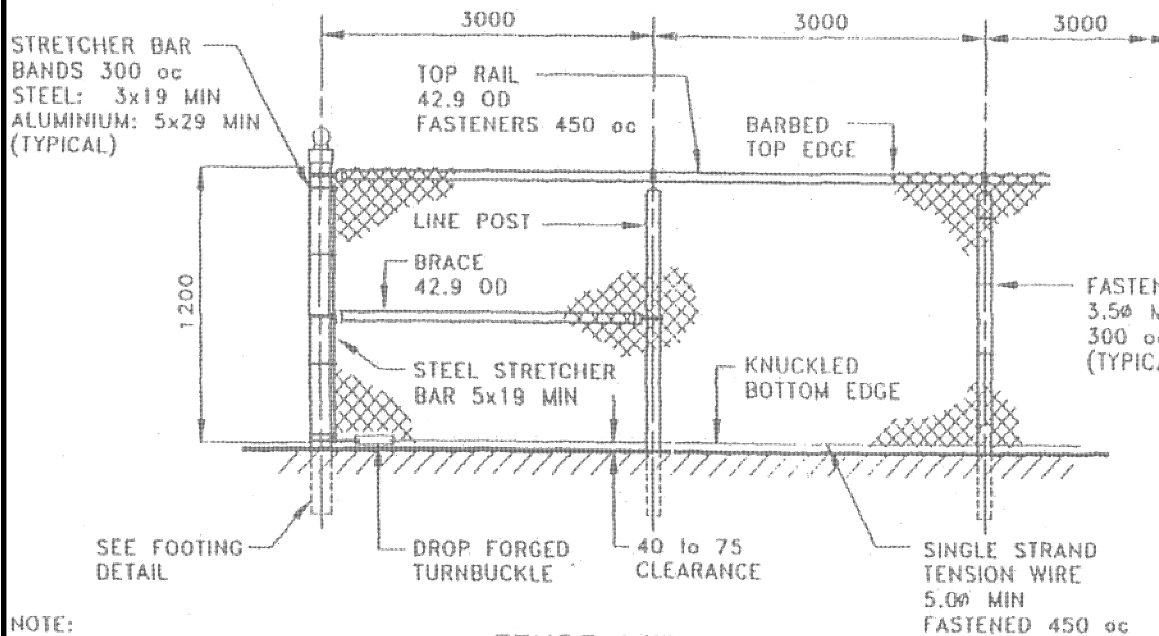

STRETCHER BAR BANDS 300 oc
STEEL: 3x19 MIN
ALUMINIUM: 5x29 MIN (TYPICAL)

FASTENERS 3.5Ø MIN ALUMINIUM 300 oc (TYPICAL)

FENCE DETAIL

NOTE:
ALL DIMENSIONS IN MILLIMETRES
UNLESS SHOWN OTHERWISE

POST DETAILS			
DESCRIPTION	OD	LENGTH	
		STANDARD	RET. WALL
LINE	60.3	2700	2000
END, CORNER, STRAINING AND GATE (WITH 5.5m MAX OPENING)	88.9	2900	2300
GATE (WITH 10.0 MAX OPENING)	114.3	2900	-

TOWNSHIP OF ZORRA

WALKWAY DETAILS

MARCH, 2005/REV.

ZSD - 9

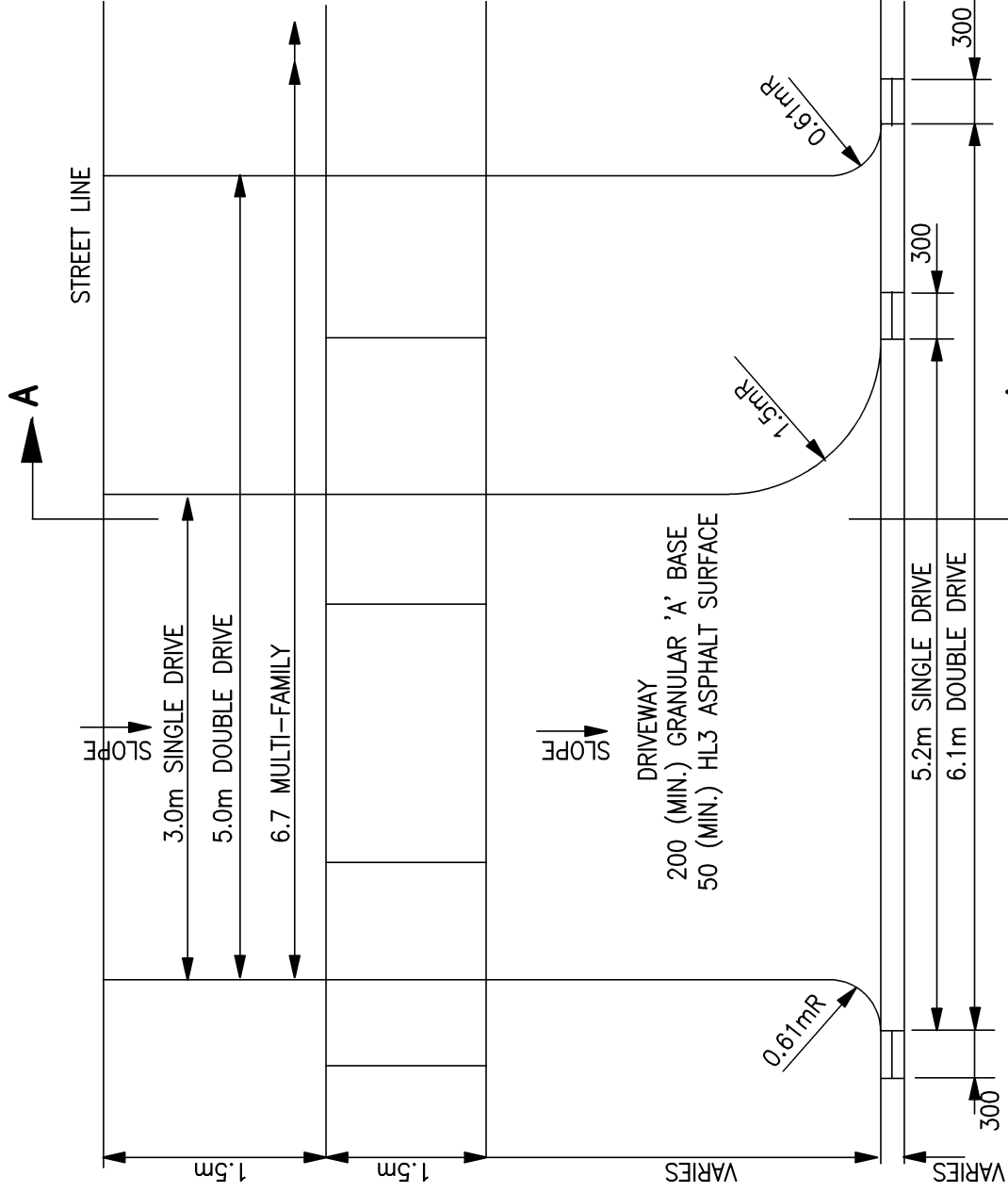

PLAN

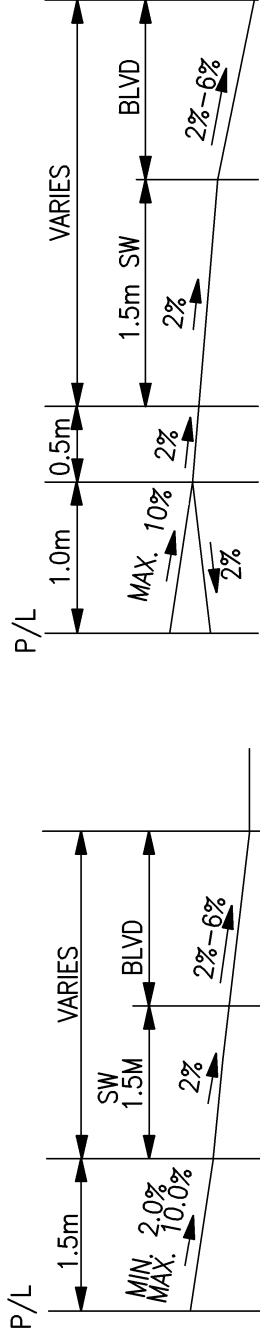

**SECTION A-A
NEW STREETS**

**SECTION A-A
EXISTING STREETS**

NOTES:

1. RADIUS OF MULTI-FAMILY DRIVEWAYS AT CURB SHALL BE: INGRESS 3.0m, EGRESS 1.8m.
2. STEEPER SLOPES ARE PERMISSIBLE WHERE BOULEVARD WIDTH IS LESS THAN 1.0m.

TOWNSHIP OF ZORRA

**RESIDENTIAL
DRIVEWAY ENTRANCE**

MARCH, 2005/REV.

ZSD - 10

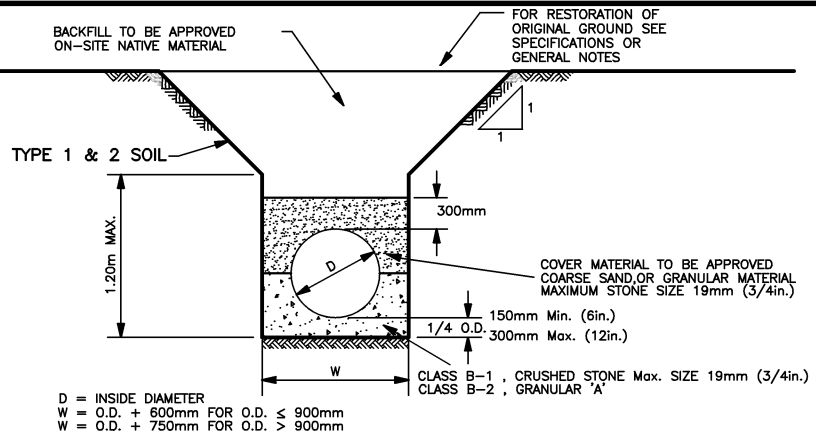

ALL BEDDING AND BACKFILL MATERIALS TO BE MECHANICALLY COMPACTED IN ACCORDANCE WITH THE CONTRACT DOCUMENTS OR GENERAL NOTES.

BEDDING DETAIL FOR RIGID SEWER PIPE CLASS B
N.T.S.

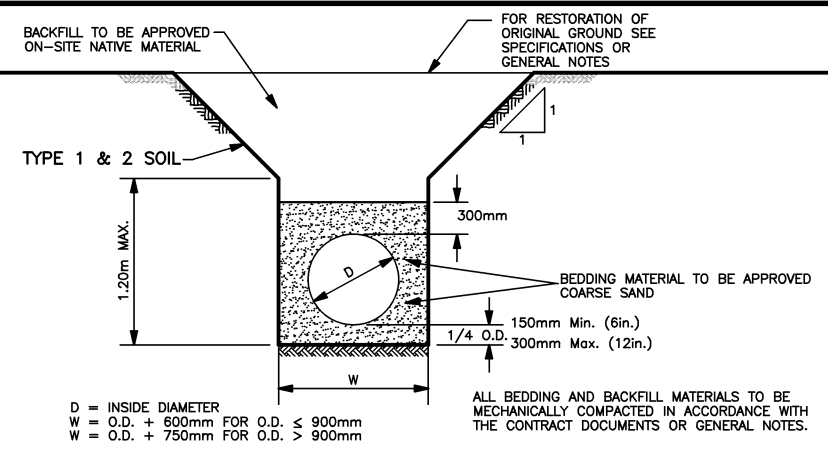

BEDDING DETAIL FOR RIGID SEWER PIPE CLASS C
N.T.S.

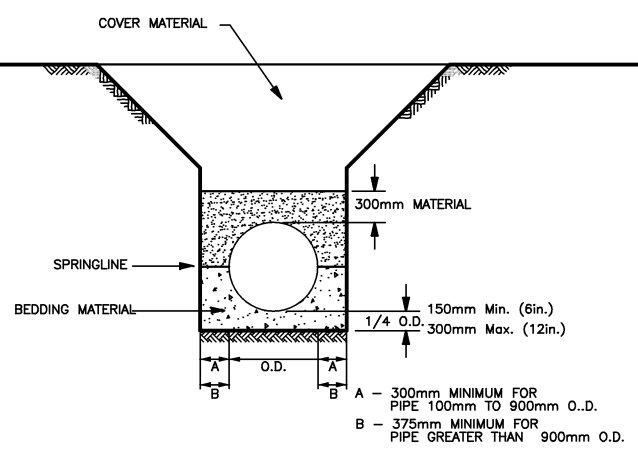

TRENCH DIMENSIONS FOR ALL PIPE SEWERS
N.T.S.

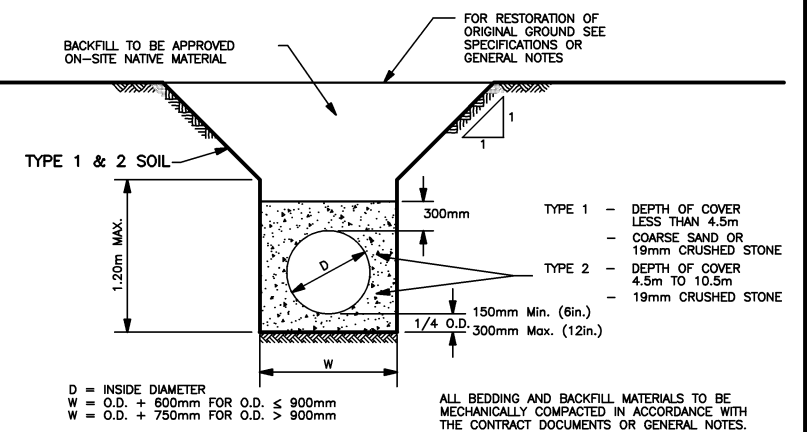

BEDDING DETAIL FOR FLEXIBLE SEWER PIPE
N.T.S.

TYPE 1 & 2 SOIL

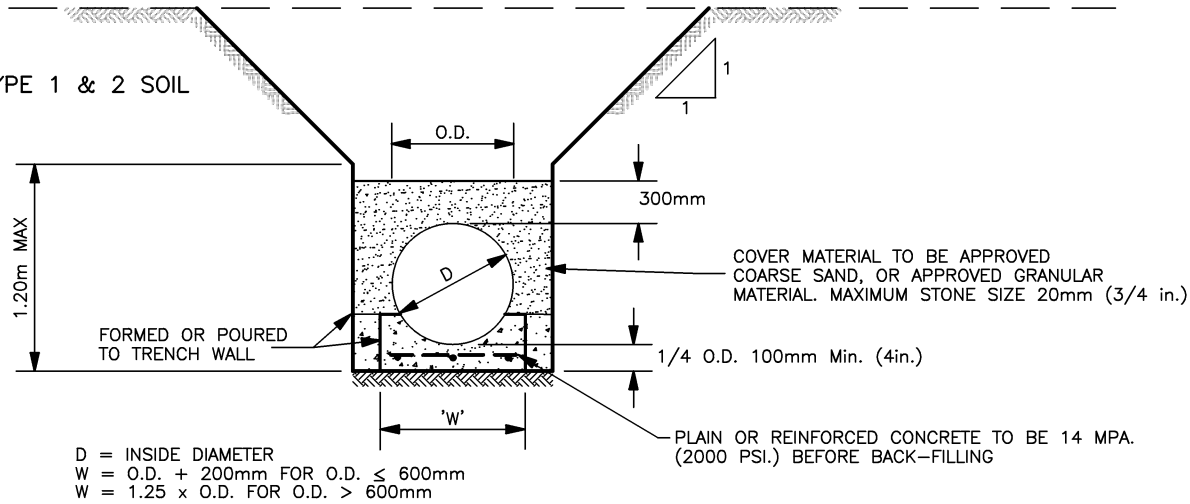

D = INSIDE DIAMETER
 W = O.D. + 200mm FOR O.D. ≤ 600mm
 W = 1.25 x O.D. FOR O.D. > 600mm

**BEDDING DETAIL FOR
 CLASS A - 1**

N.T.S.

ALL BEDDING MATERIALS TO BE MECHANICALLY
 COMPACTED IN ACCORDANCE WITH THE
 CONTRACT DOCUMENTS.

TYPE 3 SOIL

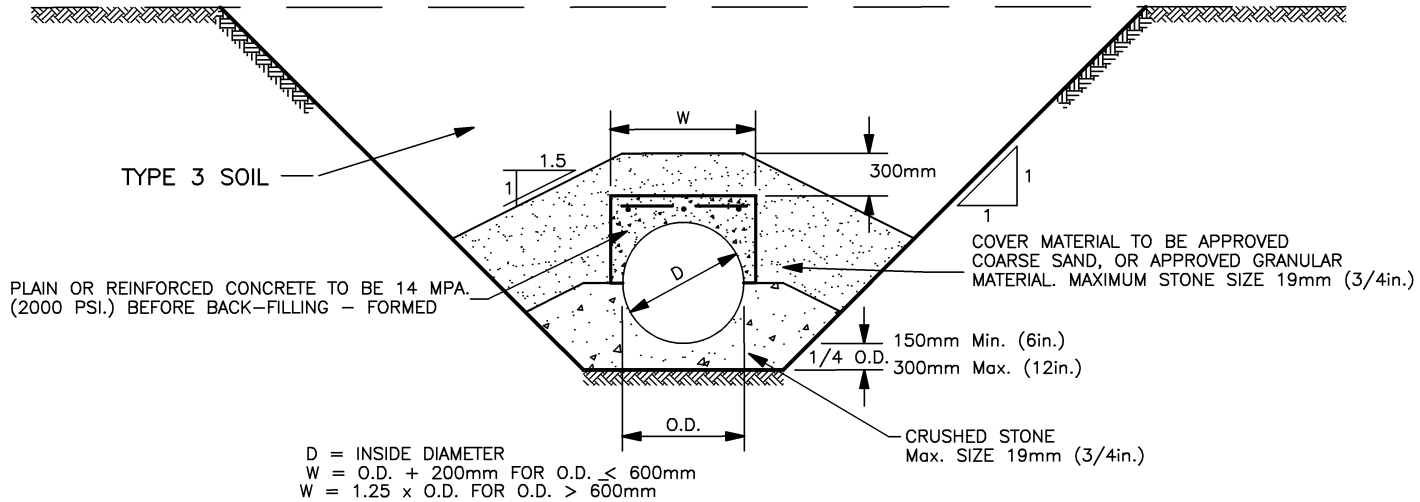

D = INSIDE DIAMETER
 W = O.D. + 200mm FOR O.D. ≤ 600mm
 W = 1.25 x O.D. FOR O.D. > 600mm

**BEDDING DETAIL FOR
 CLASS A - 2**

N.T.S.

ALL BEDDING MATERIALS TO BE MECHANICALLY
 COMPACTED IN ACCORDANCE WITH THE
 CONTRACT DOCUMENTS.

TOWNSHIP OF ZORRA

PIPE BEDDING
 DETAILS

MARCH, 2005/REV.

ZSD - 12

2% MIN. SWALE GRADE. LOCATION OF DIVISION POINT VARIES WITH ROAD SURFACE

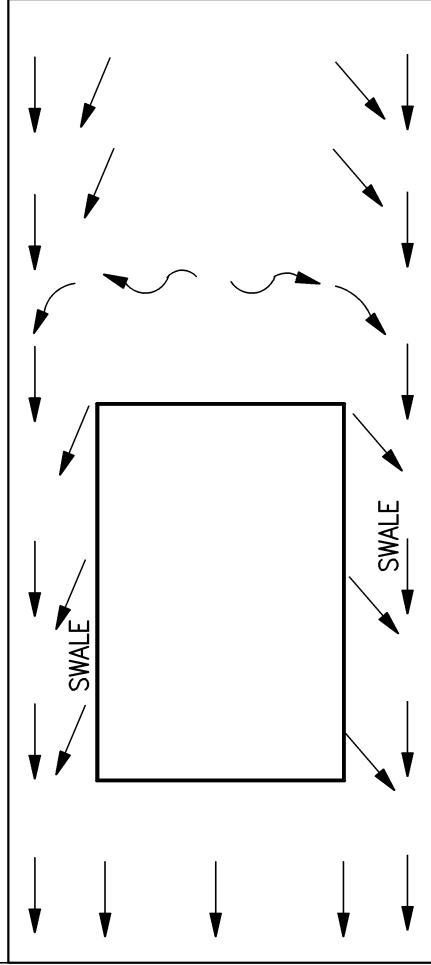

LOT LINE

SILL OF BASEMENT WINDOW TO BE 300mm ABOVE ϕ ROAD ELEV.

225 DESIRABLE 150 MIN.

6.0m
2% MIN. SLOPE VARIES
4.6m

TYPICAL FRONT LOT DRAINAGE

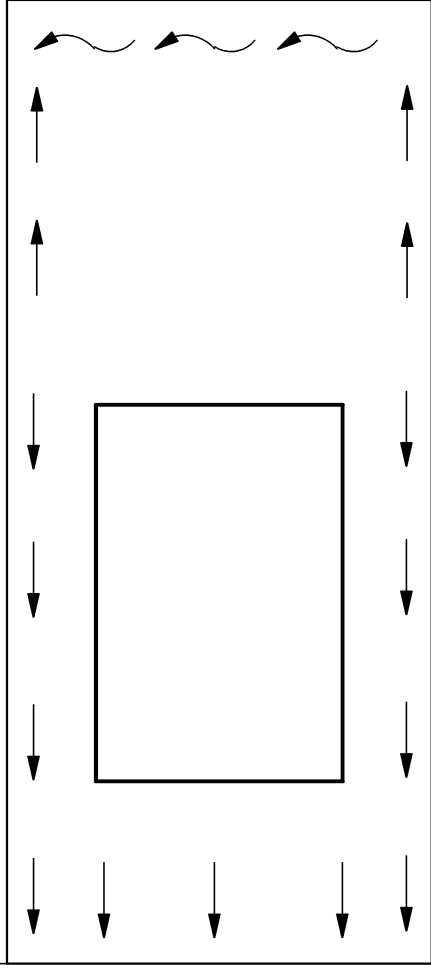

LOT LINE

DESIRABLE MIN

6.0m
VARIES
1.2m

TYPICAL REAR LOT DRAINAGE

REAR LOT ELEV. OF CORNER

NOTES:

MINIMUM LOT DIMENSIONS, FRONT YARD DEPTHS, AND SIDE YARD WIDTHS TO BE IN ACCORDANCE WITH ZONING BY-LAW.

TOWNSHIP OF ZORRA

LOT DRAINAGE PLAN

MARCH, 2005 / REV.

ZSD - 13

LEGEND:

STORM SEWER	
SANITARY (OR COMBINES) SEWER	
WATERMAIN	
WATER VALVE	
GAS MAIN	
GAS VALVE	
BELL CABLE (UNDERGROUND)	
HYDRO CABLE (UNDERGROUND)	
HYDRO, BELL, UTILITY POLES	
GUY ANCHOR	
TREE	
HEDGE, BUSH	
HYDRANT	
CATCH/CURB INLET/DITCH INLET BASIN	
BUILDING	
FENCE	
EXISTING MANHOLE	
PROPOSED MANHOLE	
PROPERTY BARS	
RADIUS	
BEGINNING/END OF CURVE	
NORTH/SOUTH STREET LINE	
BOREHOLE	
BENCH MARK	
HYDRO TOWER	
CULVERT	
DIRECTION OF FLOW/MINOR SWALE	
MAJOR/REAR YARD SWALE	
OVERLAND FLOW ROUTE	

TOWNSHIP OF ZORRA

PLAN AND PROFILE LEGEND

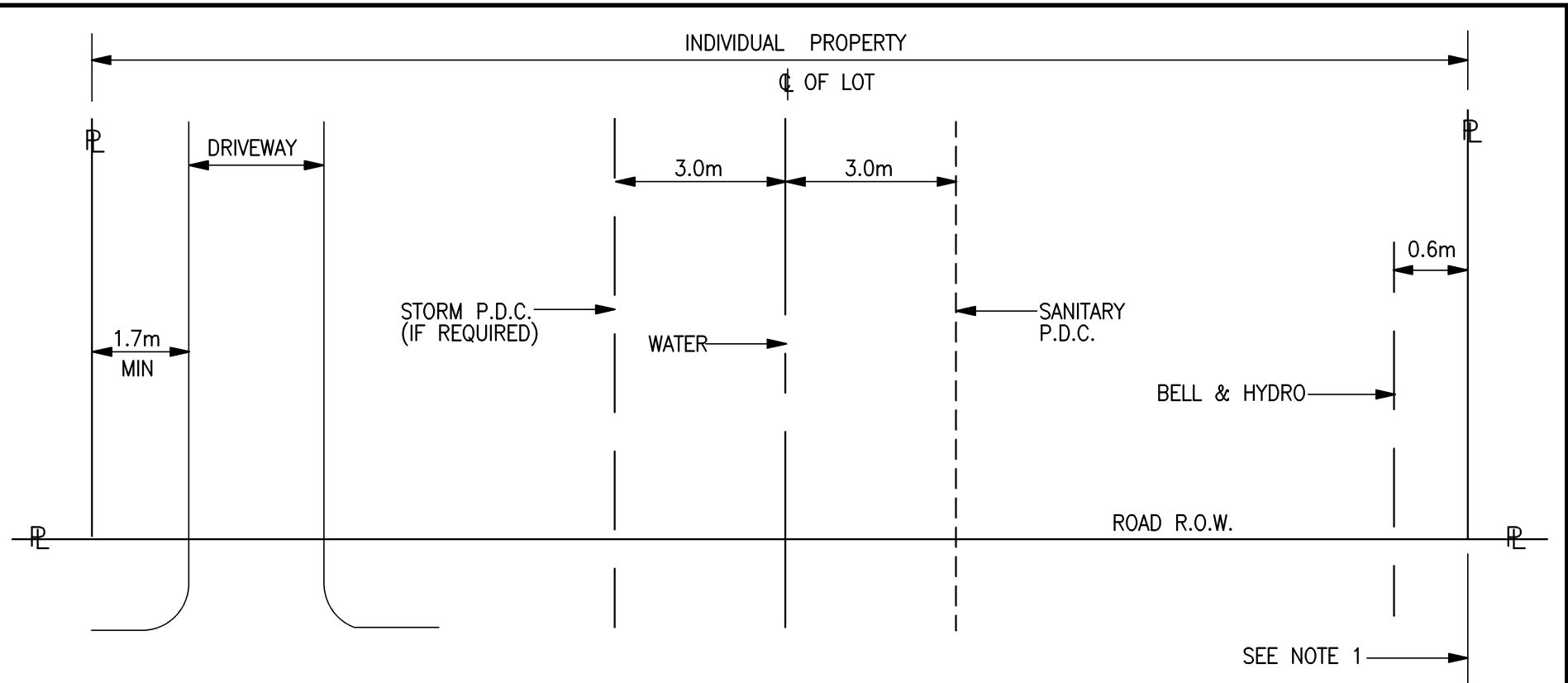

NOTES:

1. ALL HYDRANTS, PADMOUNTS TRANSFORMERS AND STREET LIGHT POLES ARE TO BE INSTALLED ON LOT LINES ONLY AND IN ACCORDANCE WITH MSD 1.
2. DRIVEWAY SHALL BE LOCATED ON THE OPPOSITE SIDE OF THE LOT TO THAT OF A PADMOUNTED TRANSFORMER.
3. WATER SERVICES SHALL BE INSTALLED ON THE CENTRELINE OF SINGLE LOTS, AND 1.0m TO THE RIGHT AND LEFT OF CENTERLINE FOR SEMI-DETACHED LOTS.
4. SANITARY P.D.C. SHALL BE INSTALLED 3.0m RIGHT OF CENTERLINE FOR SINGLE LOTS AND 3.0m RIGHT AND LEFT OF CENTERLINE FOR SEMI-DETACHED LOTS.
5. BELL AND HYDRO TO BE INSTALLED IN COMMON TRENCH 0.6m FROM EITHER PROPERTY LINE.

TOWNSHIP OF ZORRA	
LOT SERVICING	
MARCH, 2005/REV.	ZSD - 15

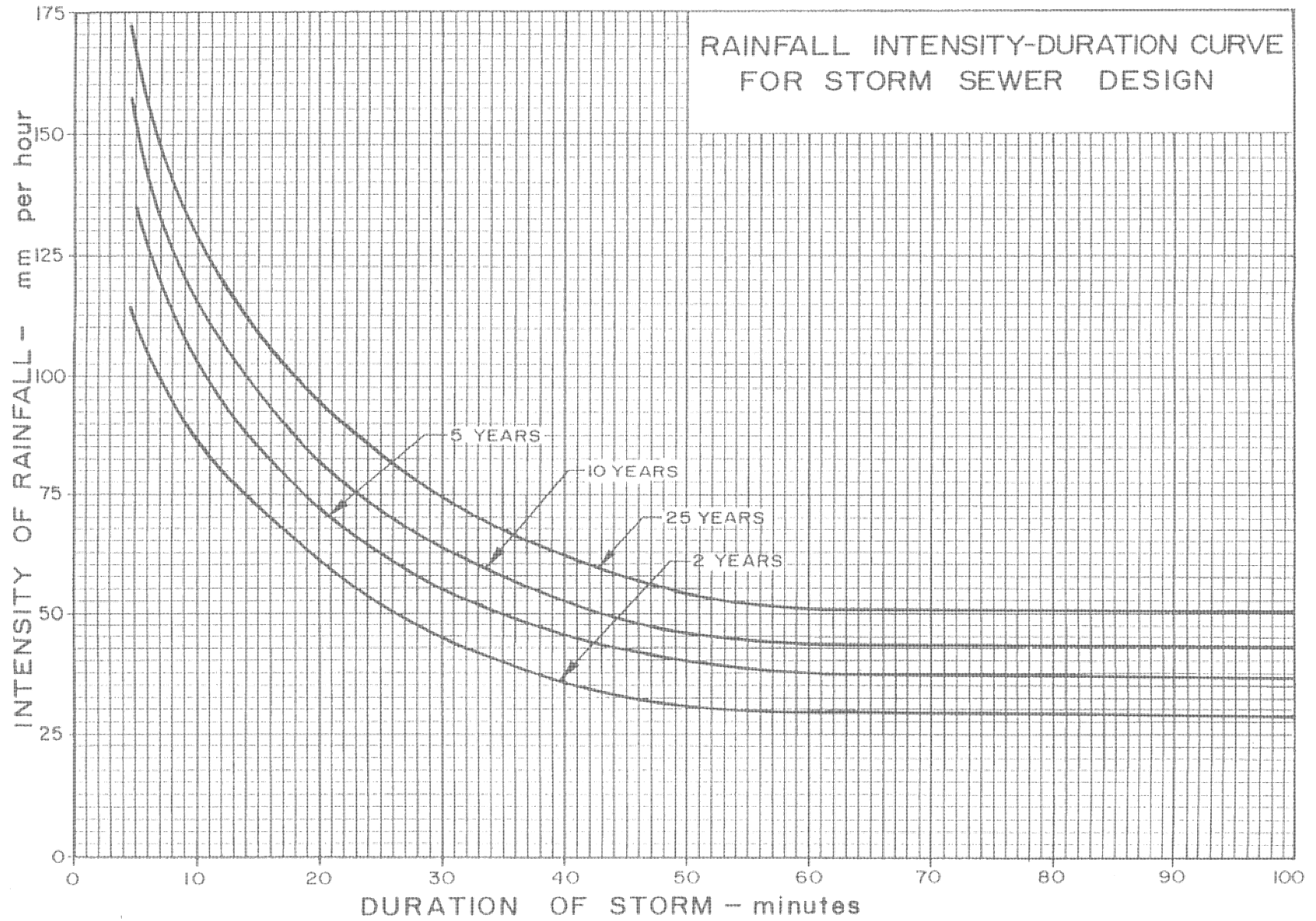

TOWNSHIP OF ZORRA

RAINFALL INTENSITY
DURATION CURVES

MARCH, 2005/ REV

ZSD - 16

**CULVERT AND STORMWATER MANAGEMENT DESIGN
RAINFALL INTENSITY CHART
AES DESIGN STORM (LONDON AIRPORT 1943-1986)**

$$I = a / (t + b)^c$$

	2 year	5 year	10 year	25 year	50 year	100 year
a=	724.69	1330.31	1497.19	1455.00	1499.06	1499.53
b=	5.500	7.938	7.188	5.000	4.188	3.297
c=	0.800	0.855	0.850	0.820	0.809	0.794

Time (min)	Intensity (mm/hr)	Intensity (mm/hr)	Intensity (mm/hr)	Intensity (mm/hr)	Intensity (mm/hr)	Intensity (mm/hr)
5	110.46	149.04	178.75	220.22	249.21	279.47
10	80.89	112.71	133.46	157.93	175.35	192.17
15	64.68	91.34	107.42	124.74	137.36	149.15
20	54.32	77.17	90.38	103.88	113.89	123.12
30	41.68	59.41	69.25	78.84	86.08	92.72
45	31.44	44.68	51.92	58.84	64.14	69.01
60	25.54	36.10	41.89	47.45	51.71	55.67
90	18.89	26.41	30.61	34.76	37.92	40.91
120	15.18	21.01	24.35	27.76	30.32	32.79
360	6.45	8.52	9.89	11.53	12.70	13.90
720	3.73	4.75	5.53	6.57	7.28	8.05
1440	2.15	2.64	3.08	3.73	4.17	4.65

TOWNSHIP OF ZORRA	
SWM RAINFALL INTENSITY CHART	
MARCH, 2005/REV.	ZSD - 17

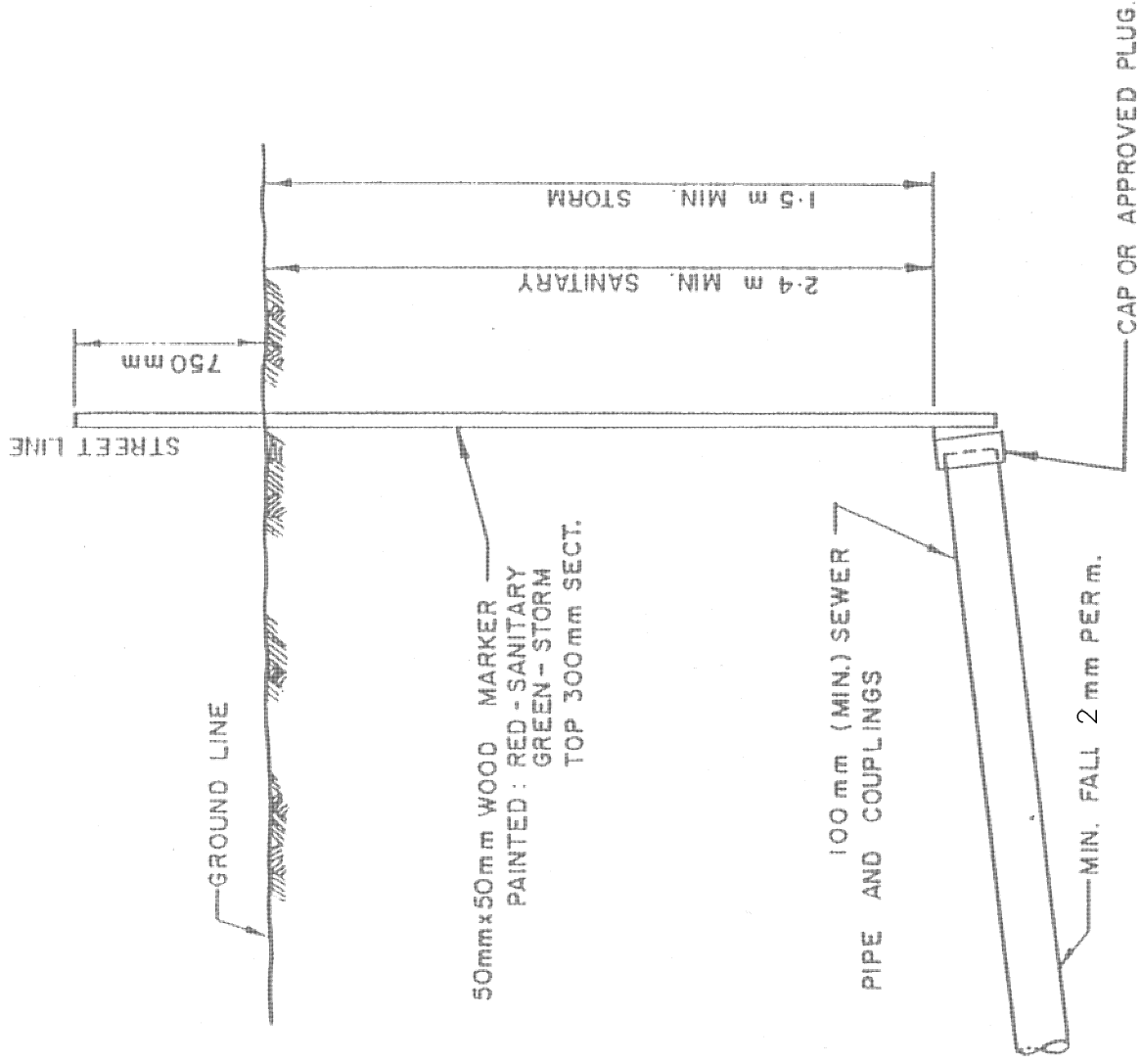

TOWNSHIP OF ZORRA

**PRIVATE DRAIN CONNECTIONS
 AT STREET LINE**

MARCH, 2005/REV.

ZSD - 18

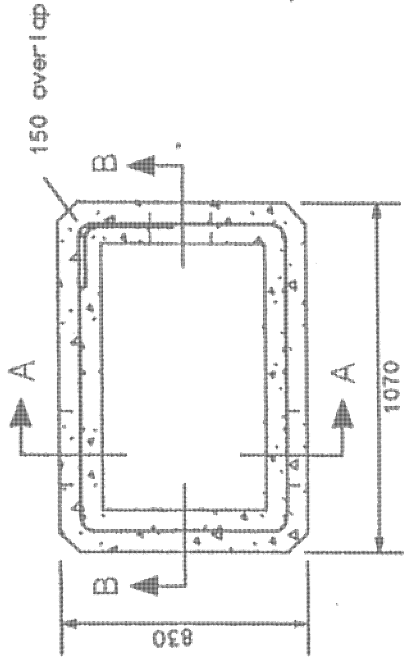

PLAN

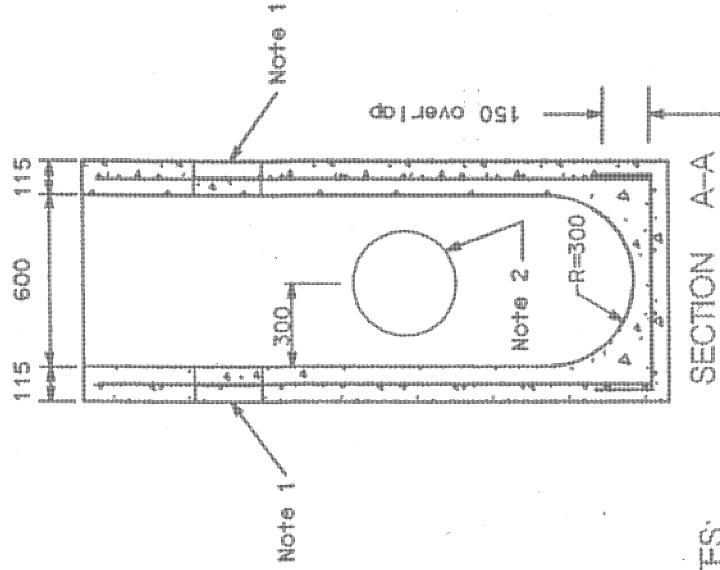

SECTION A-A

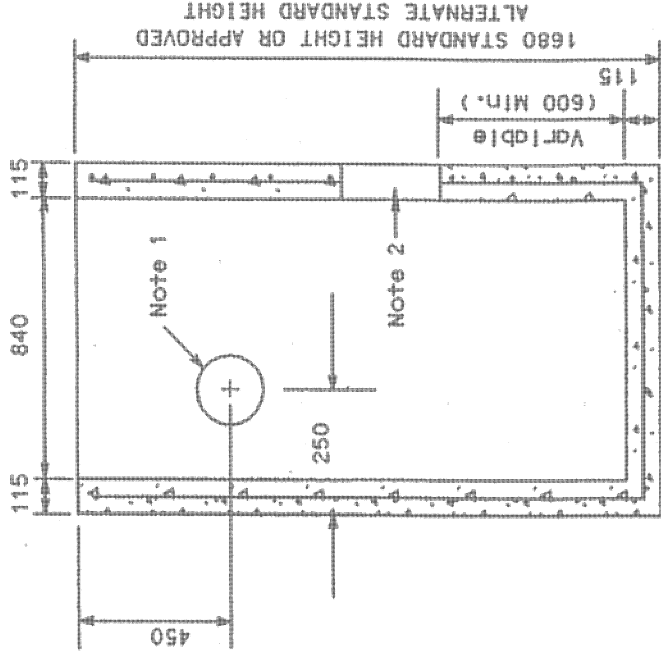

SECTION B-B

NOTES:

1. 200mm dia. knockout to accommodate subdrain. Knockout to be half wall thickness from the outside.
2. Outlet hole size 400mm dia. location as required.
3. All reinforcing steel bars to be 15. Reinforcing steel shall have 50mm cover

A. ALL DIMENSIONS ARE IN MILLIMETERS UNLESS OTHERWISE SHOWN

4. Granular backfill to be placed and compacted to a min. thickness of 300mm all around
5. Adjustment units shall be installed as per QPSD-704.010.
6. Class of concrete: 30 MPa at 28 days
7. Refer to QPSD-400.09 for catch basin cast iron curb inlet overflow plate details.

TOWNSHIP OF ZORRA

600x840 PRECAST CONCRETE CURB INLET CATCHBASIN

MARCH, 2005/REV.

ZSD - 19

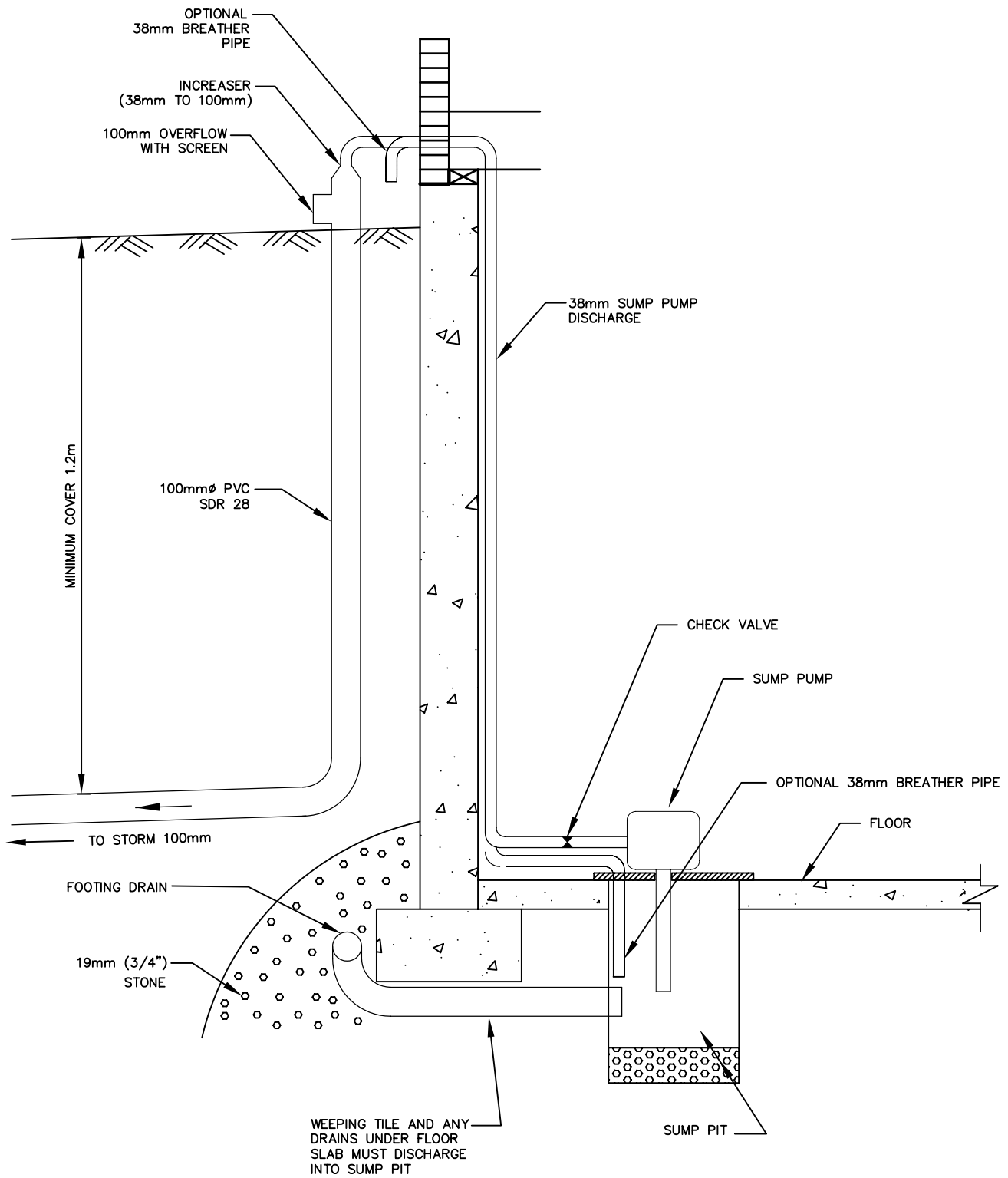

NOTES

1. BACKWATER VALVES SHOULD BE INSPECTED BY HOMEOWNER SEMI ANNUALLY.
2. A SEPARATE BUT PARALLELING 38mm DIA BREATHER PIPE FROM THE SUMP PUMP PIT MAY BE DESIRABLE.

TOWNSHIP OF ZORRA	
DETAIL FOR STORM CONNECTION	
SCALE : 1:20	FIGURE 1
DATE: SEPT 2010	